

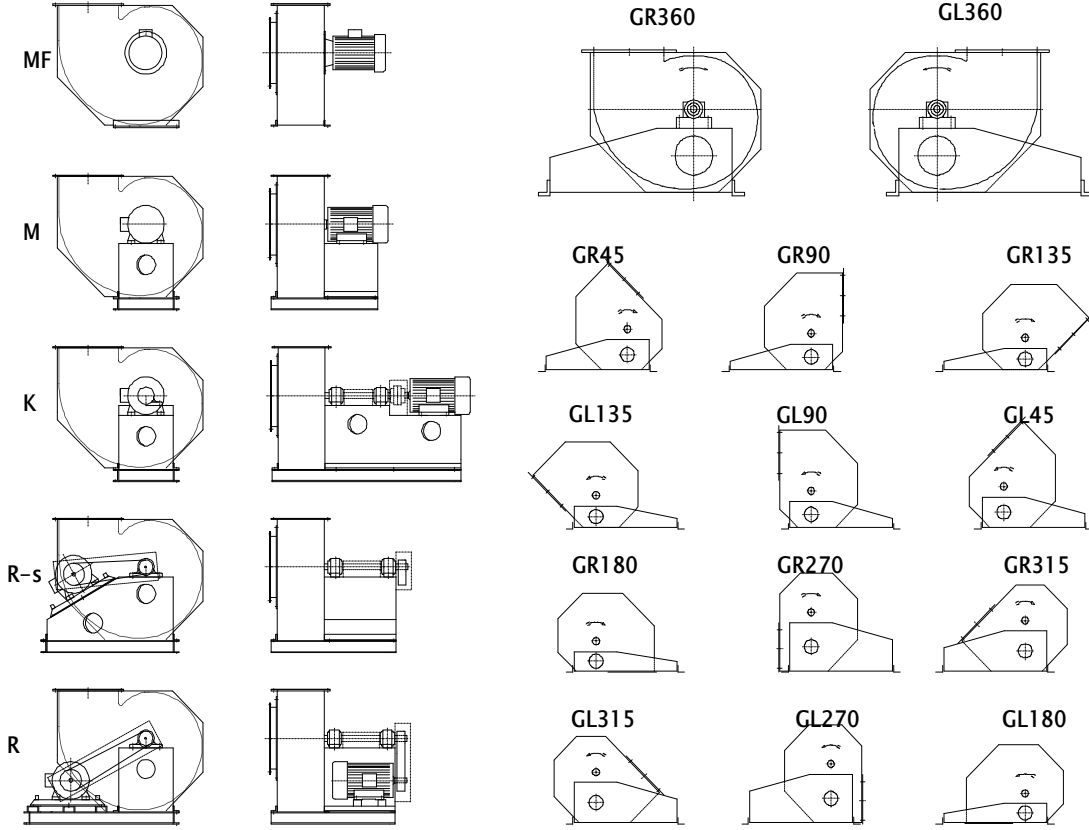

Tahrik ve duruş şekilleri



Standart gösterim:

BAA a ex / R U 200 M GR360

1 2 3 4 5 6 7 8

1 = Seri tanımı

2 = Rotor

3 = Exproof koruma

4 = Konstriksiyon

5 = Bağlantı şekli

6 = Tip

7 = Tahrik şekli

8 = Duruş şekli

a = Standart rotor, z.B. = Kuvvetlendirilmiş rotor (interdisc)

R = Tek Emişli, Z = Çift Emişli

U = Direkt borulu emiş bağlantısı (İstenirse flanşlı),

E = Emişte boru yok, S = Emiş kutusu

MF Direkt akuple B5 flanşlı motor ile

M Direkt akuple motor altlığı B3 motor ile

K Kaplin bağlantılı

KG Özel kaplin bağlantılı (Dişli kutusu ile)

R Kayış kasnak tahrikli motor alt şasede

R-s Kayış kasnak tahrikli motor yan şasede



BAA Tipi Yüksek Verimli Radyal Vantilatörler Ebat Tablosu

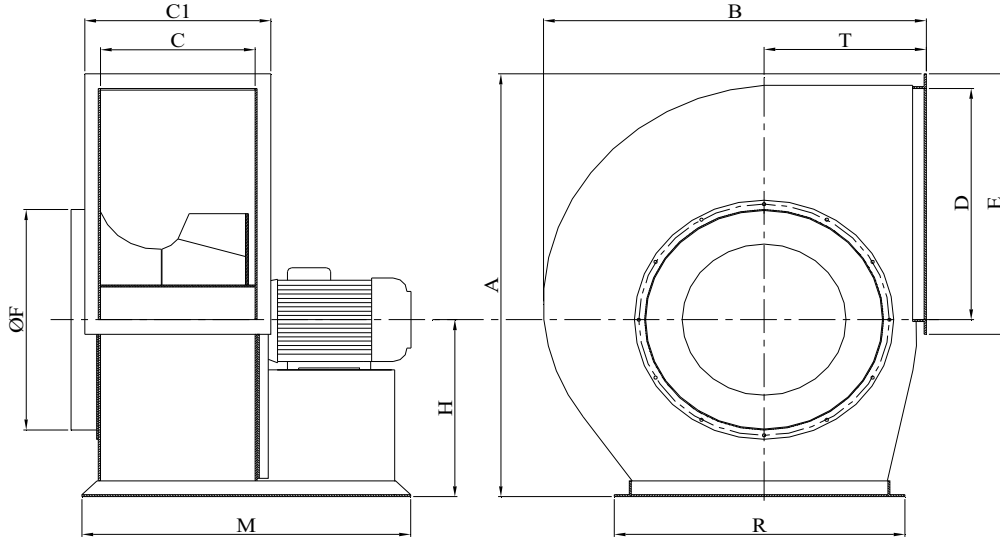

Tip	Motor Gücü ve Devri		A mm	B mm	C mm	C1 mm	D mm	E mm	ØF mm	H mm	M mm	R mm	T mm
	kW	d/d											
125	0.25	1450	625	550	230	295	330	390	305	265	475	405	250
	1.1	2850	625	550	230	295	330	390	305	265	485	405	250
135	0.25	1450	685	578	230	295	370	430	350	285	475	445	257
	2.2	2850	685	578	230	295	370	430	350	285	535	445	257
150	0.37	1450	776	663	290	355	415	475	390	331	535	497	292
	4	2850	776	663	290	355	415	475	390	331	655	497	292
165	0.75	1450	830	703	325	390	450	510	425	350	580	531	302
	5.5	2850	830	703	325	390	450	510	425	350	710	531	302
185	1.1	1450	910	782	354	420	495	555	465	385	654	592	342
	7.5	2850	910	782	354	420	495	555	465	385	770	592	342
200	2.2	1450	985	833	395	460	545	605	510	410	740	631	357
210	3	1450	1055	893	415	500	575	655	540	438	760	661	386
225	4	1450	1100	932	433	518	605	685	565	455	798	690	401
245	5.5	1450	1214	1033	478	563	665	745	625	507	863	750	462
260	7.5	1450	1270	1080	505	590	700	780	635	530	960	800	462
270	11	1450	1337	1125	532	618	735	815	685	562	1088	848	477
300	15	1450	1457	1235	586	672	815	895	735	602	1192	920	522

Tahrik şekli direkt akuple olan tiplerin ebat tablosudur. Diğer tipler için bizimle temas kurunuz.

BAA 125

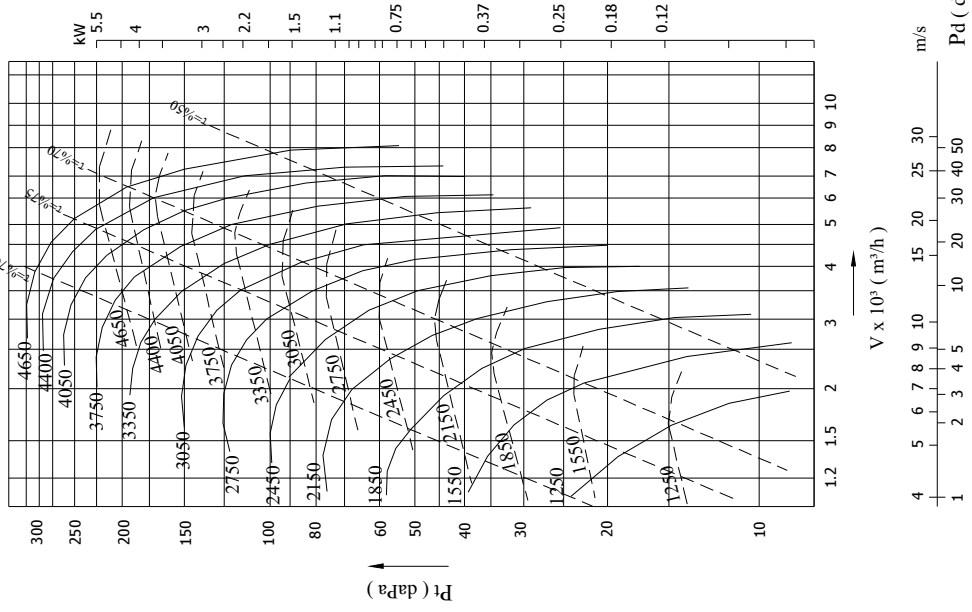

BAA 135

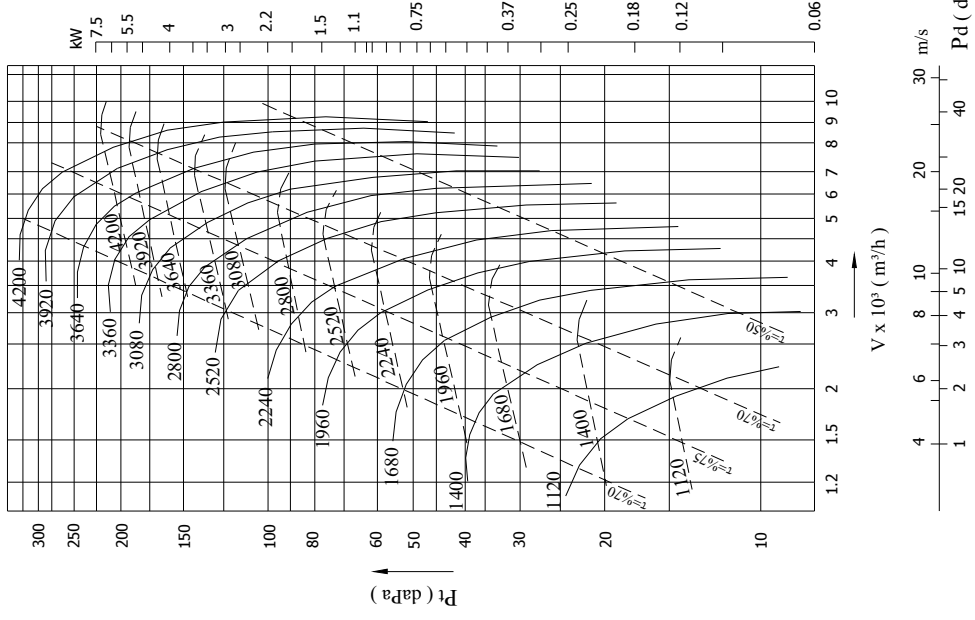

BAA 150

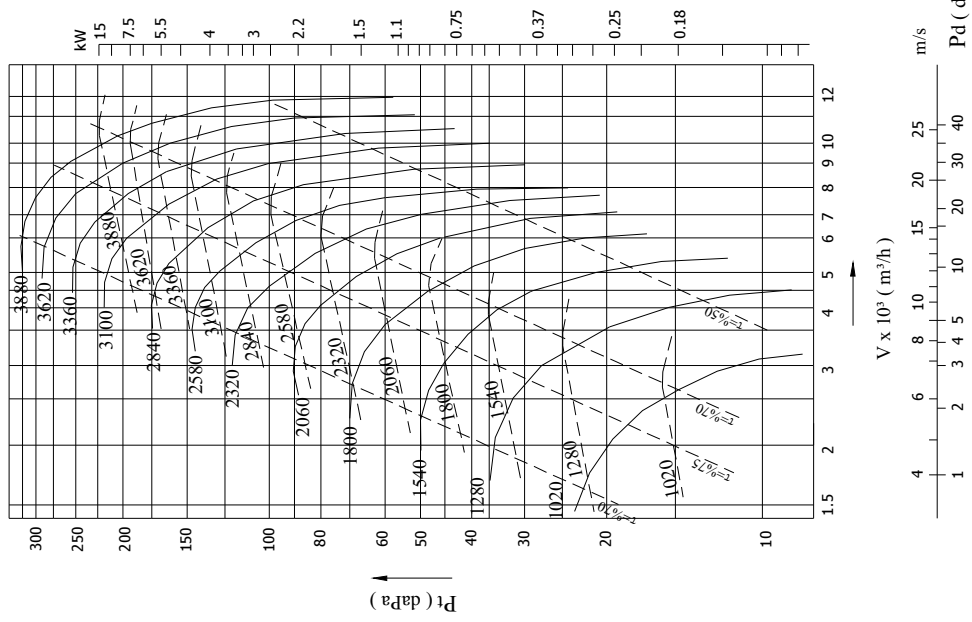

BAA 165

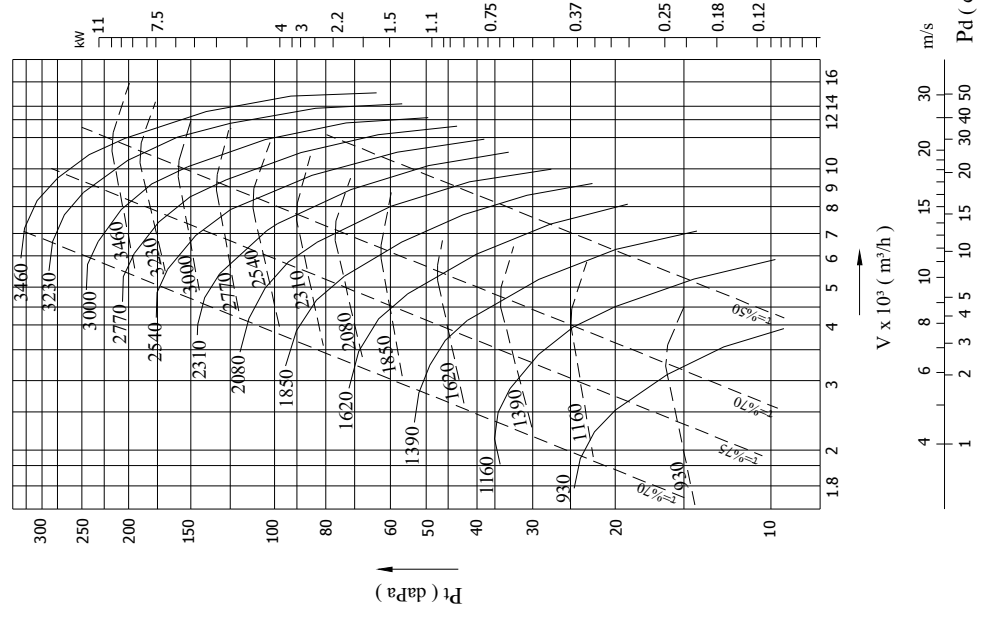

BAA 185

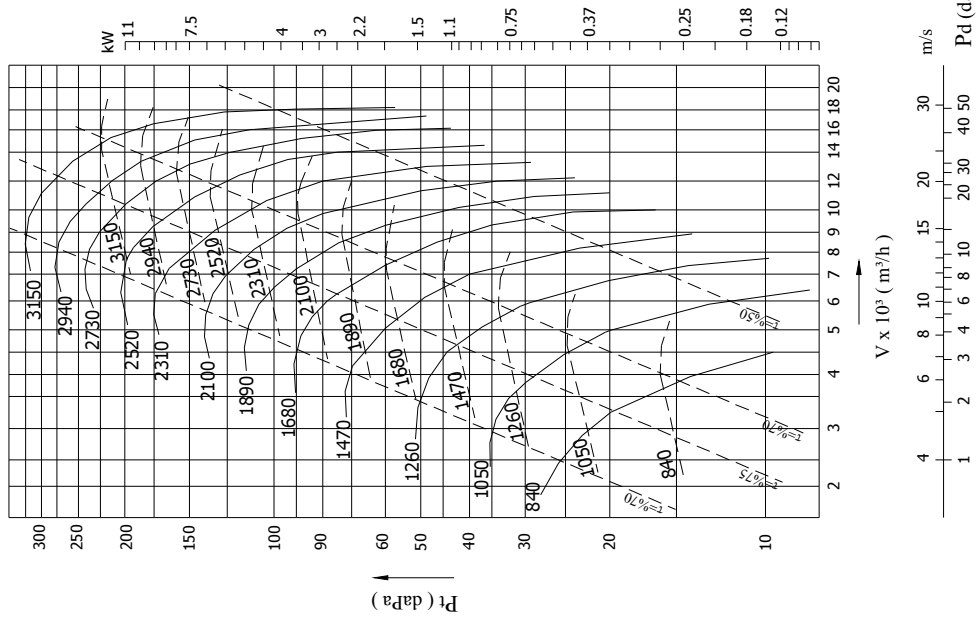

BAA 200

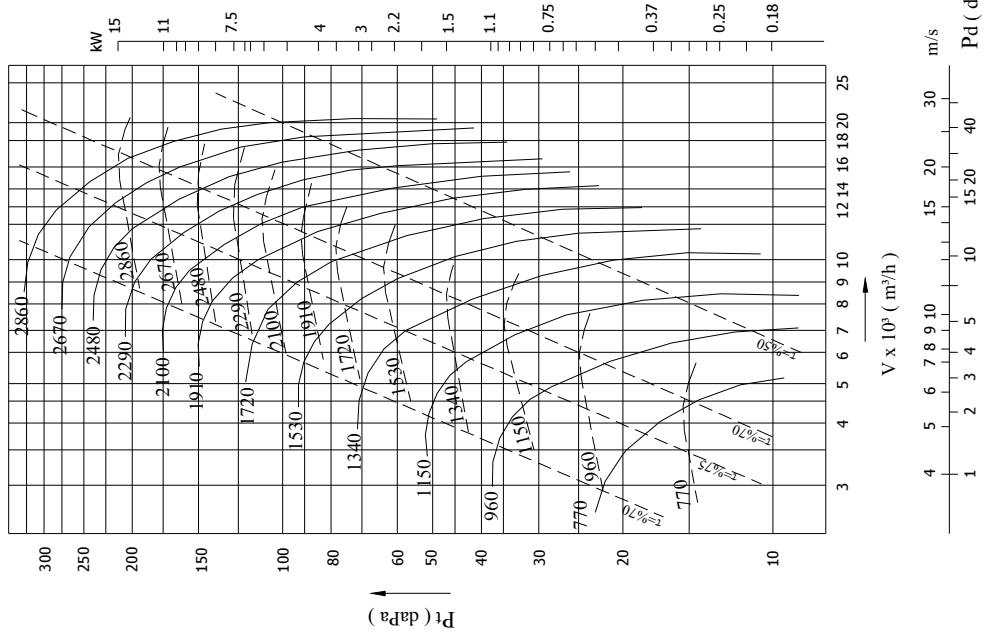

BAA 210

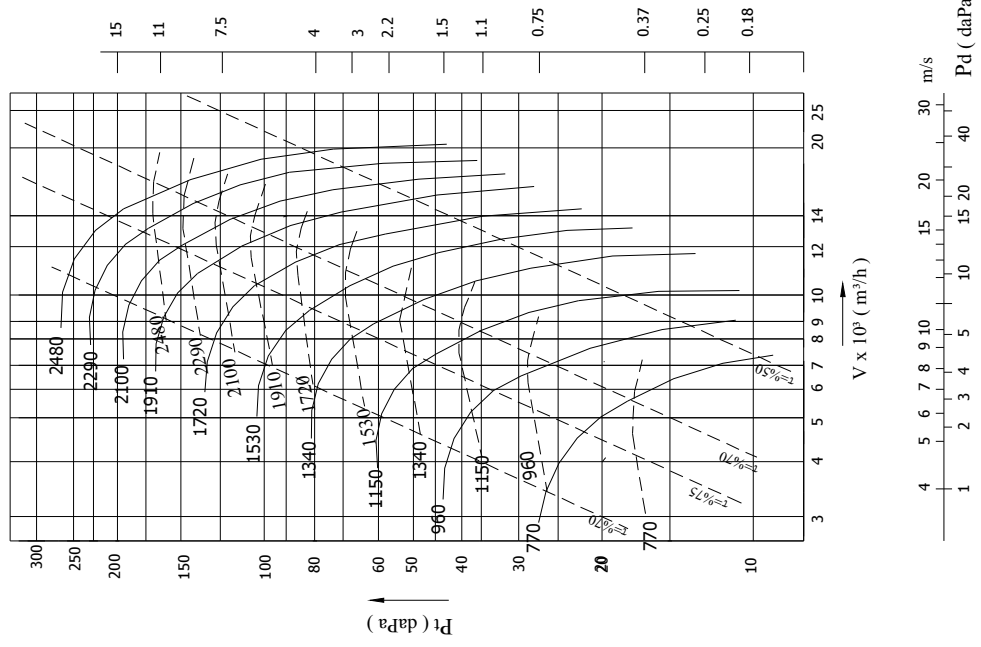

BAA 225

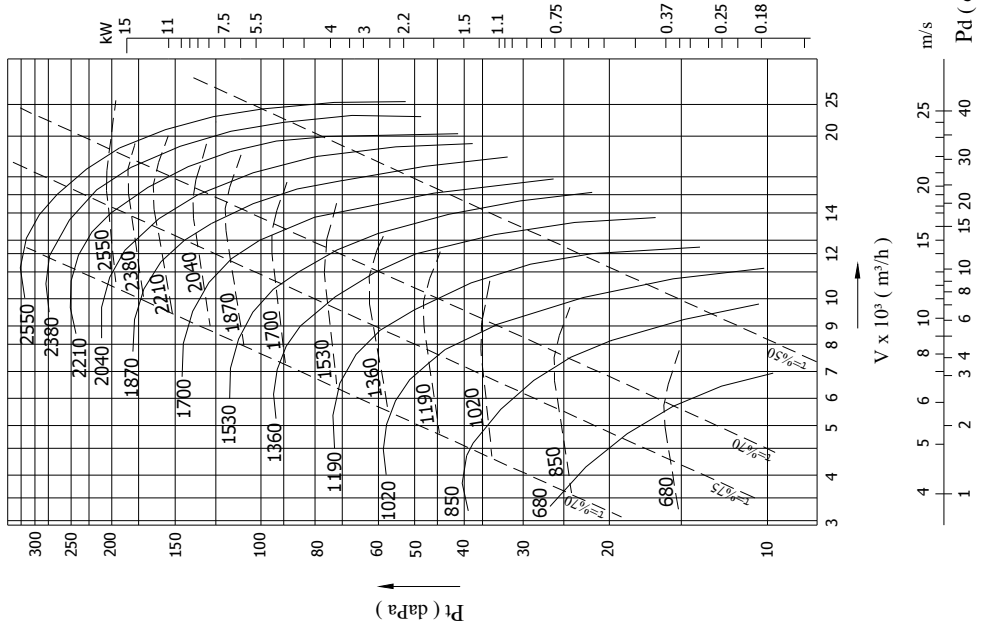

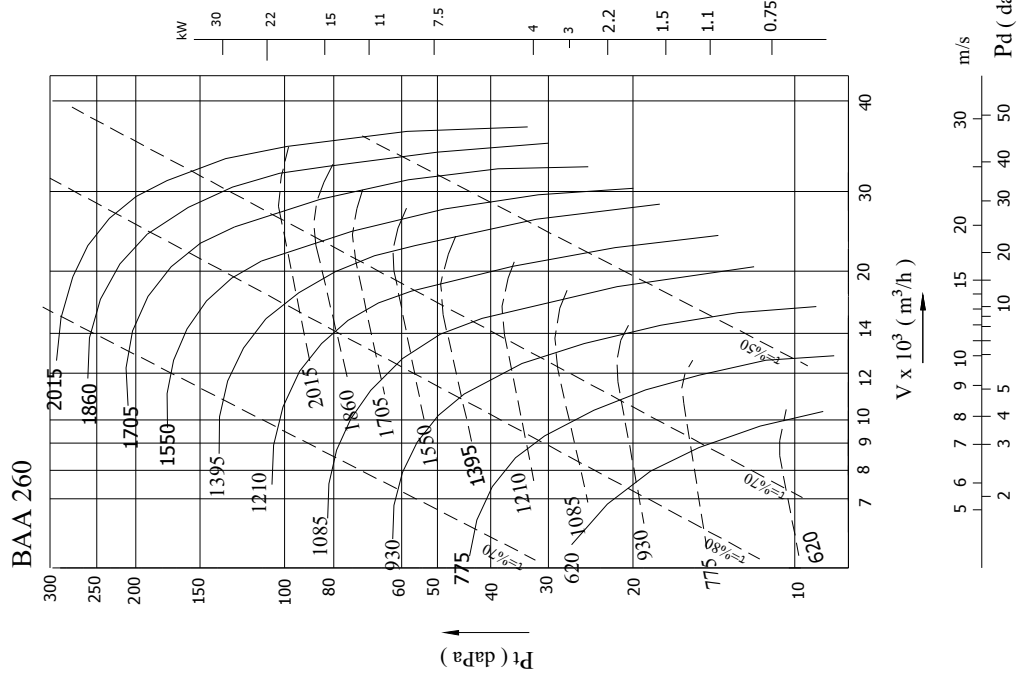
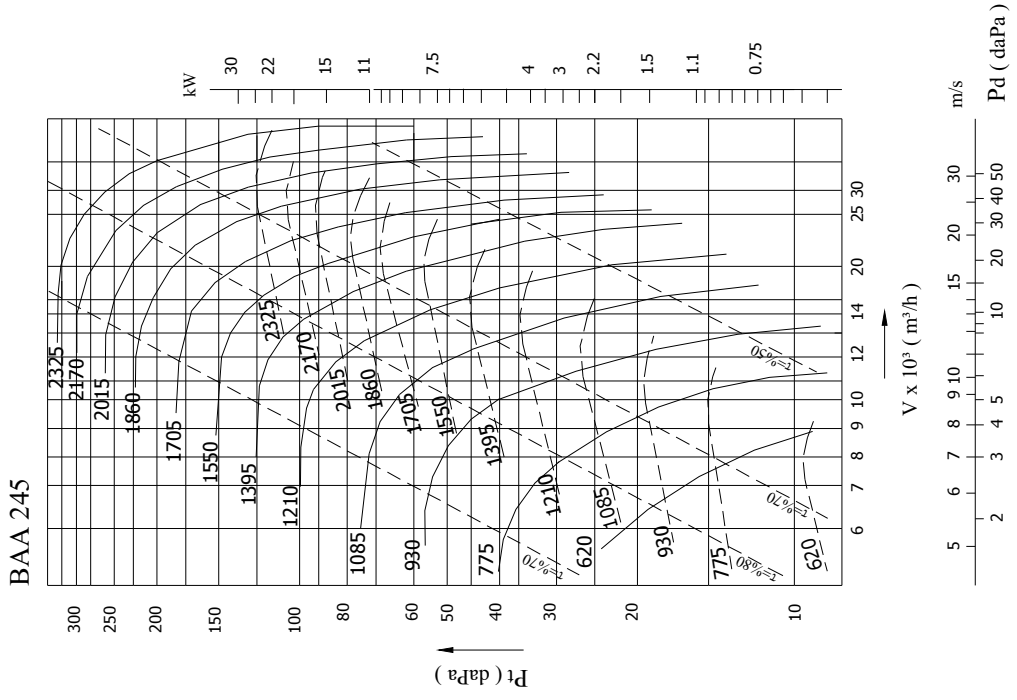

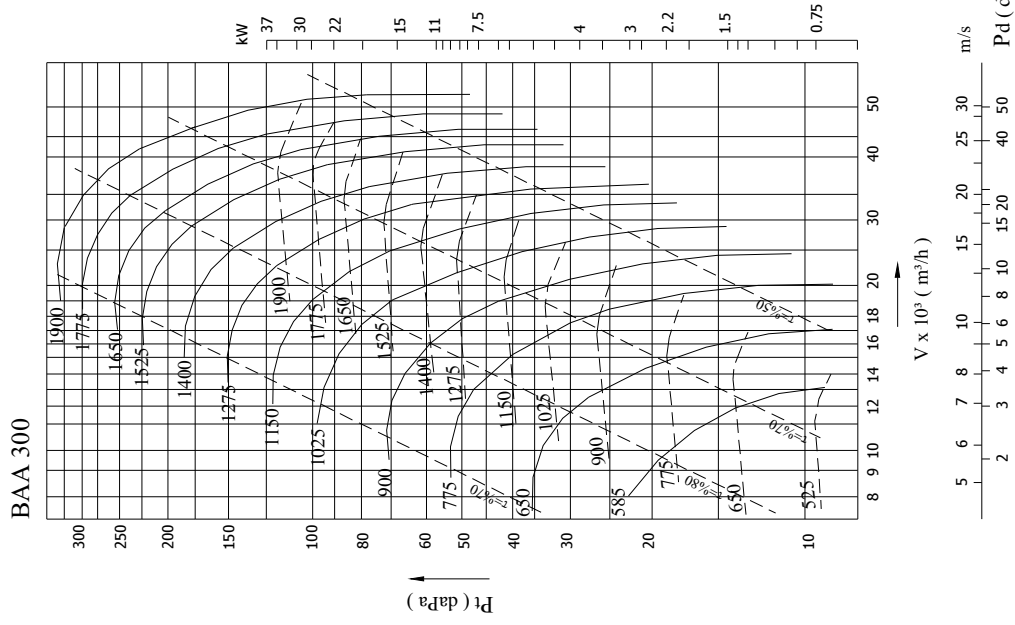
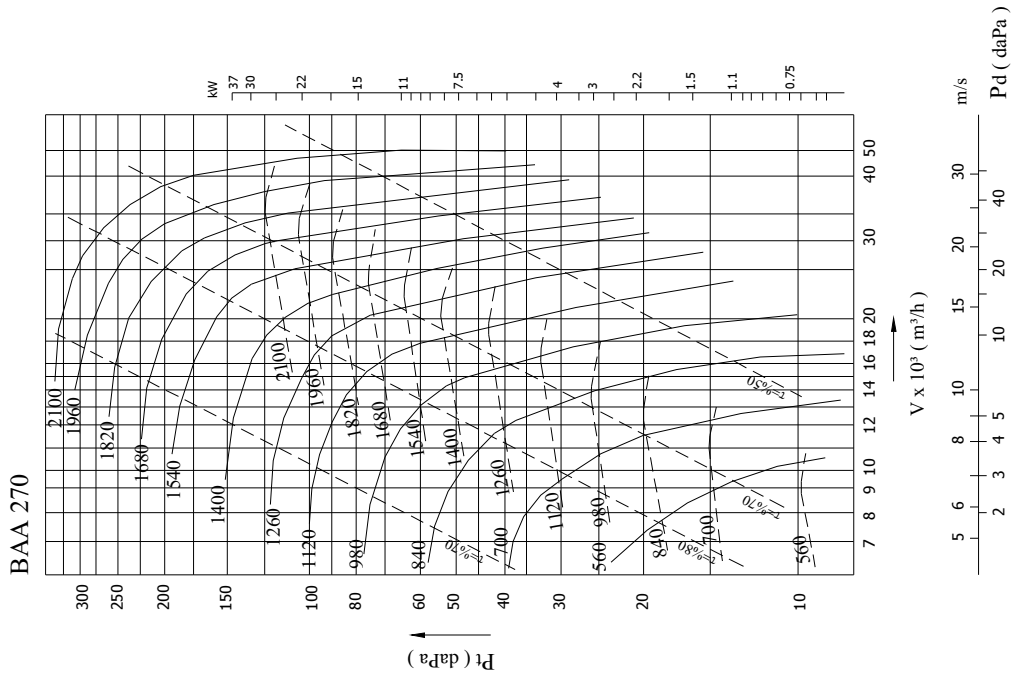

BAA 330

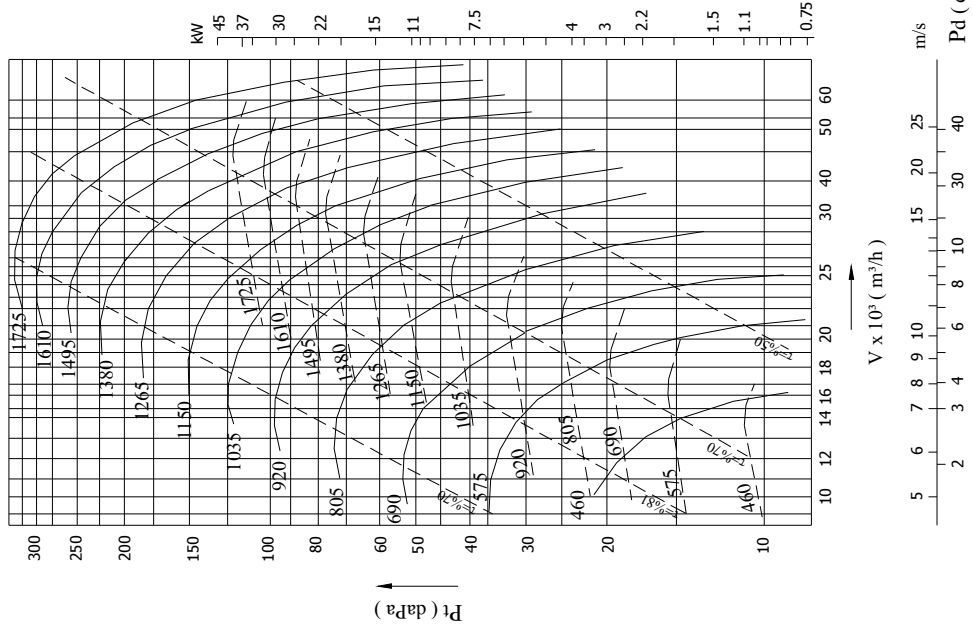

BAA 365

