

**PA 02**

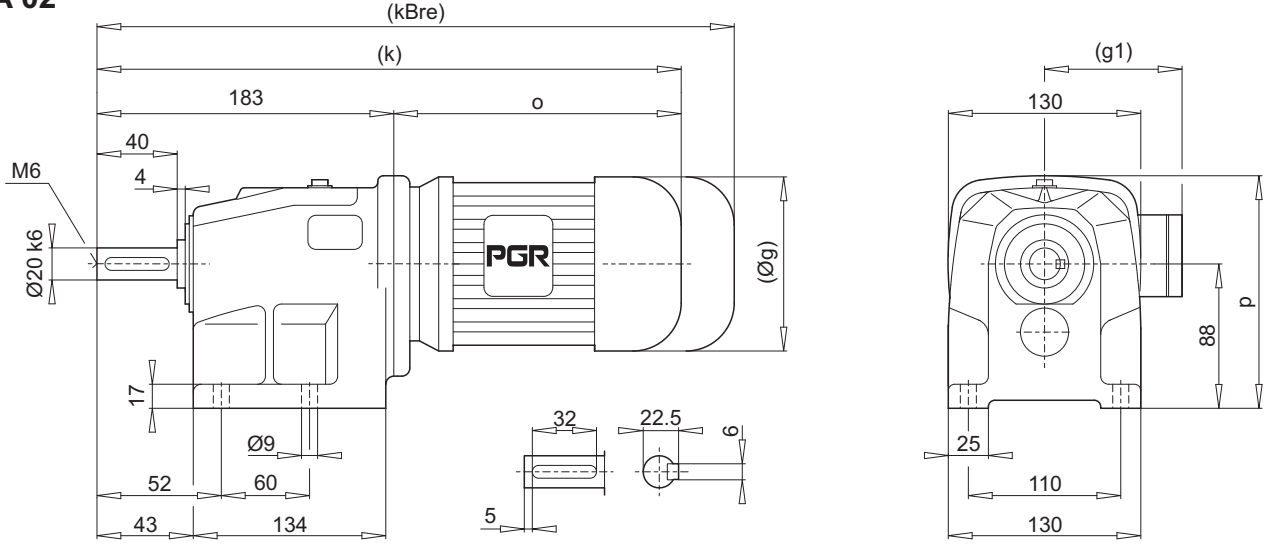

**PF 02**

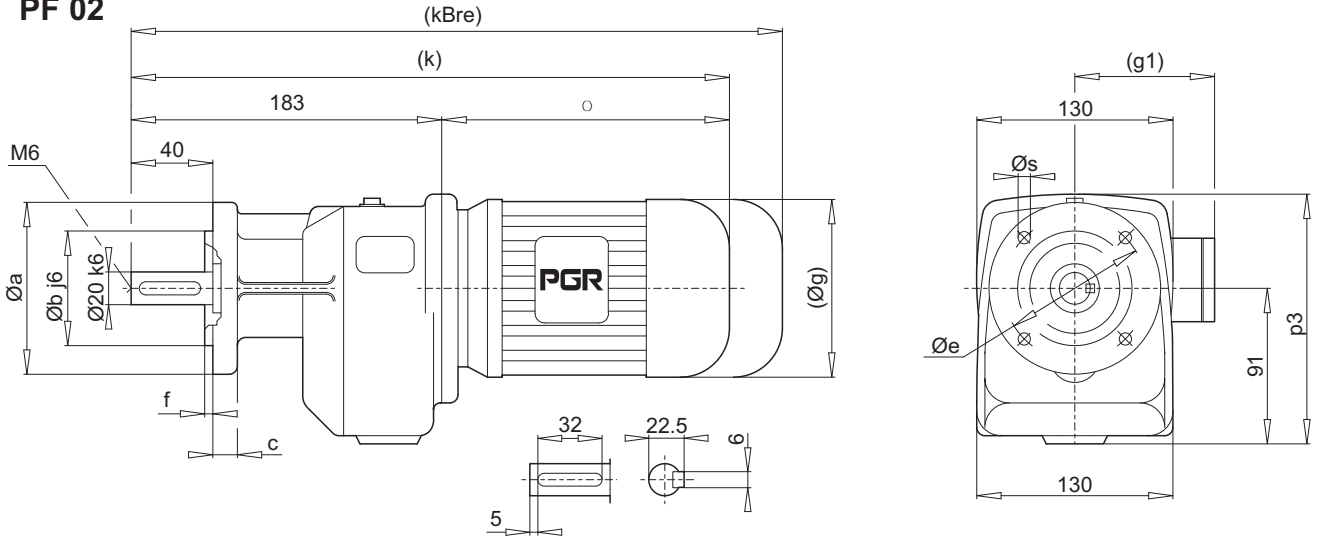

a	b	c	e	f	s
120	80	11	100	3.0	7
140	95	11	115	3.0	9
160	110	11	130	3.5	9

	63 M	71 M	80 M	90 S/L				
g	124	140	159	193				
g1	111	119	127	151				
k	381	423	450	473/493				
kBre	433	483	512	546/566				
o	198	240	267	290/310				
p	152	160	170	180				
p3	155	163	173	183				

**Not : (...)** İşaretili olan ölçüler Motor markasına göre farklılık gösterir.  
Note : Dimension which is designated by (...) depends on marks of motor.

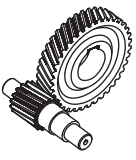

**PA 03**

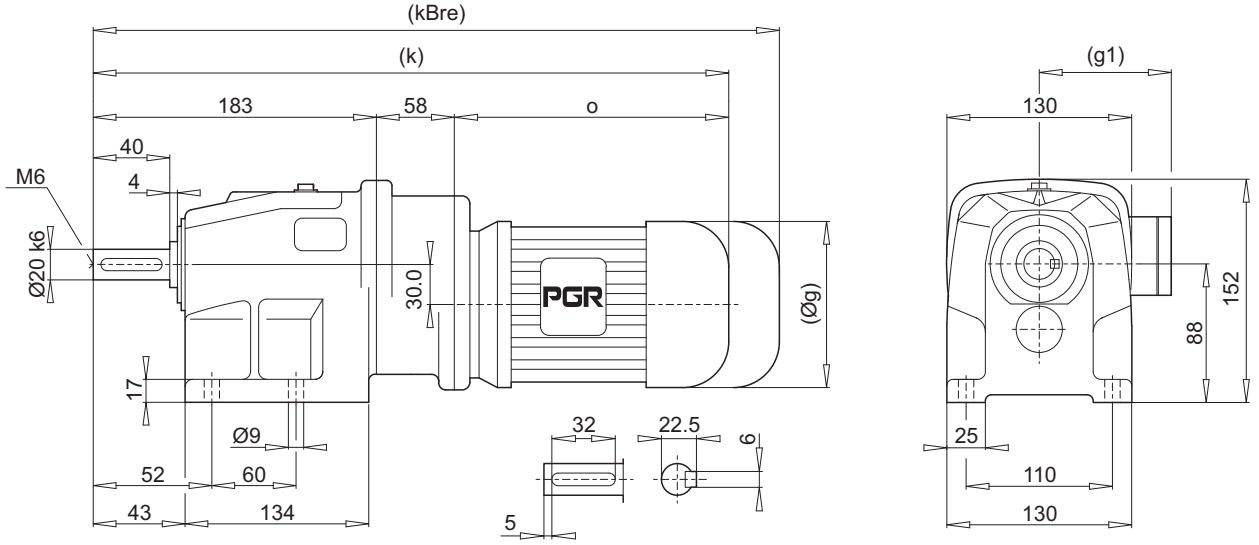

**PF 03**

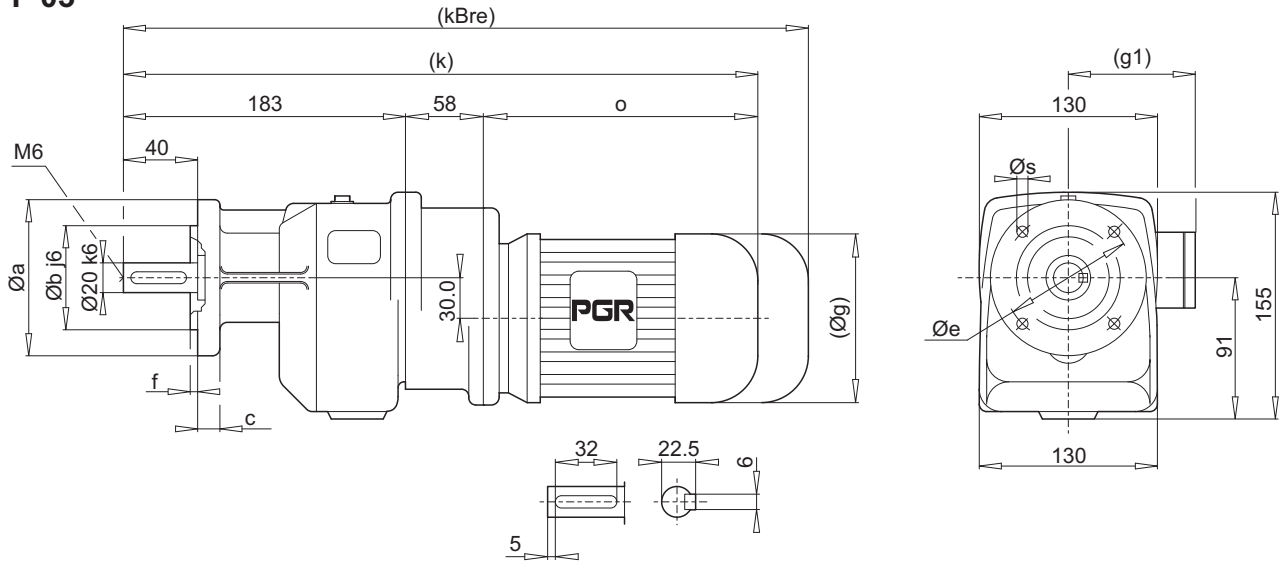

a	b	c	e	f	s
120	80	11	100	3.0	7
140	95	11	115	3.0	9
160	110	11	130	3.5	9

	63 M	71 M						
g	124	140						
g1	111	119						
k	439	481						
kBre	491	541						
o	198	240						

**Not : (...)** İşaretili olan ölçüler Motor markasına göre farklılık gösterir.  
Note : Dimension which is designated by (...) depends on marks of motor.

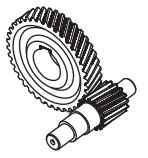

**PA 12**

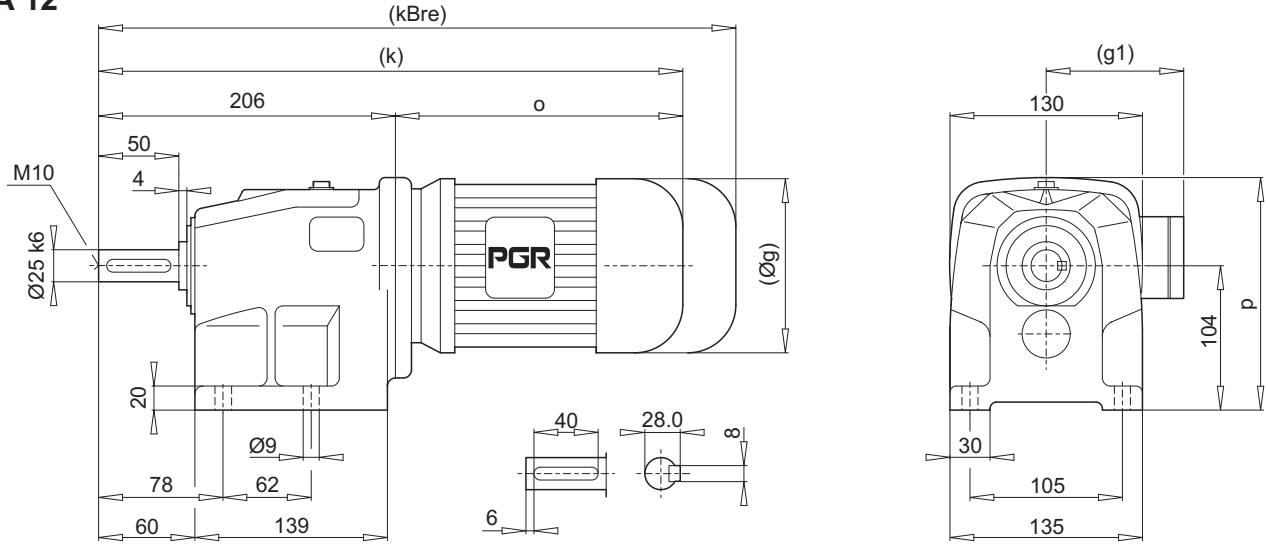

**PF 12**

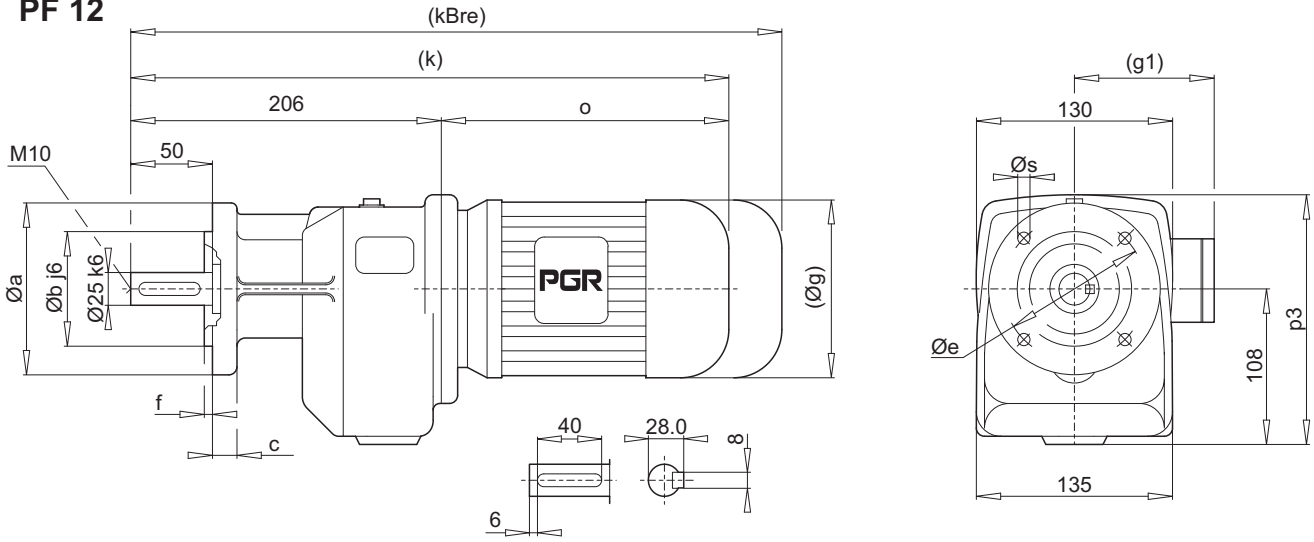

a	b	c	e	f	s
120	80	13	100	3.0	7
140	95	13	115	3.0	9
160	110	13	130	3.5	9

	63 M	71 M	80 M	90 S/L	100 L	112 M		
g	124	140	159	193	217	232		
g1	111	119	127	151	160	168		
k	404	446	473	496/516	544	589		
kBre	456	506	535	569/589	625	669		
o	198	240	267	290/310	338	383		
p	169	176	186	196	205	216		
p3	175	180	190	200	209	220		

**Not : (...)** İşaretili olan ölçüler Motor markasına göre farklılık gösterir.  
Note : Dimension which is designated by (...) depends on marks of motor.

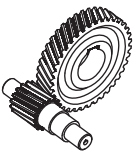

**PA 13**

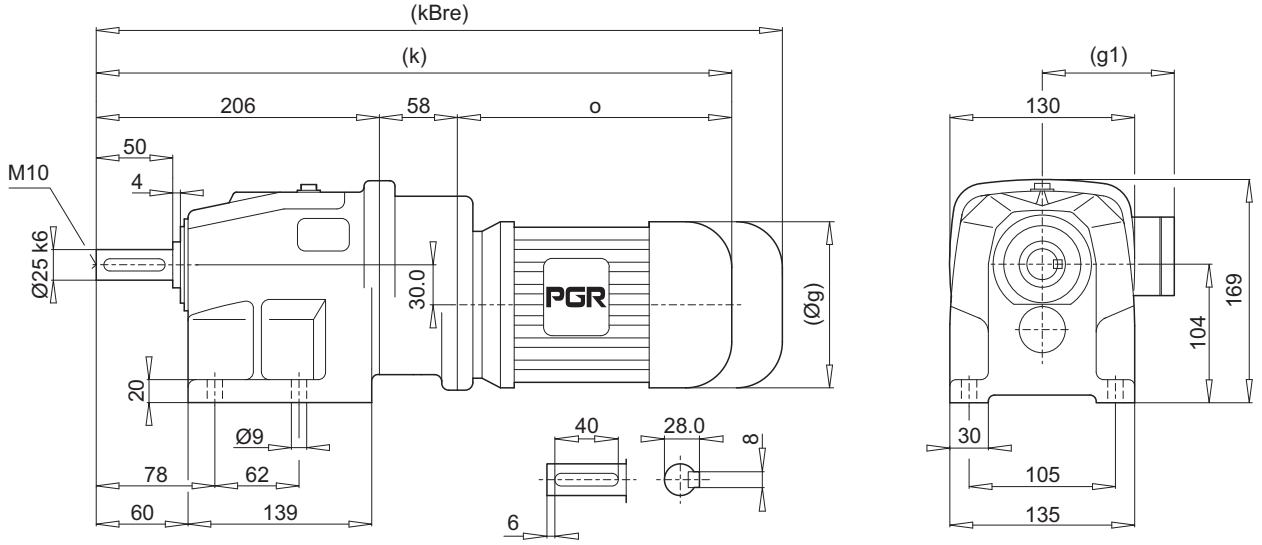

**PF 13**

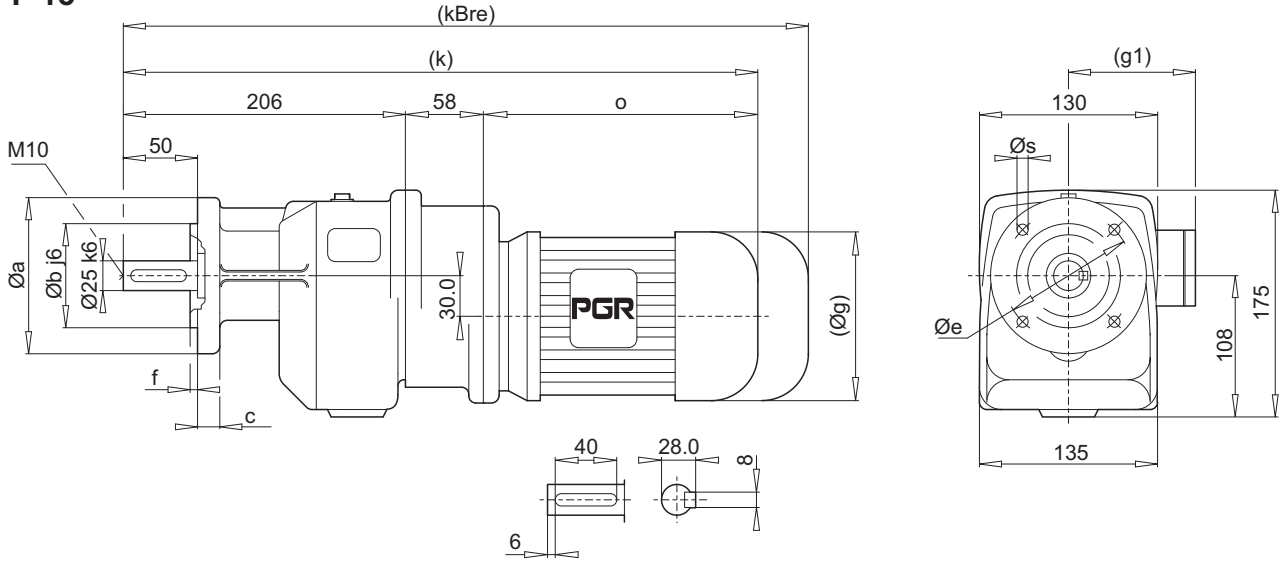

a	b	c	e	f	s
120	80	13	100	3.0	7
140	95	13	115	3.0	9
160	110	13	130	3.5	9

	63 M	71 M					
g	124	140					
g1	111	119					
k	462	504					
kBre	514	564					
o	198	240					

**Not : (...)** İşaretili olan ölçüler Motor markasına göre farklılık gösterir.  
Note : Dimension which is designated by (...) depends on marks of motor.



**PA 22**

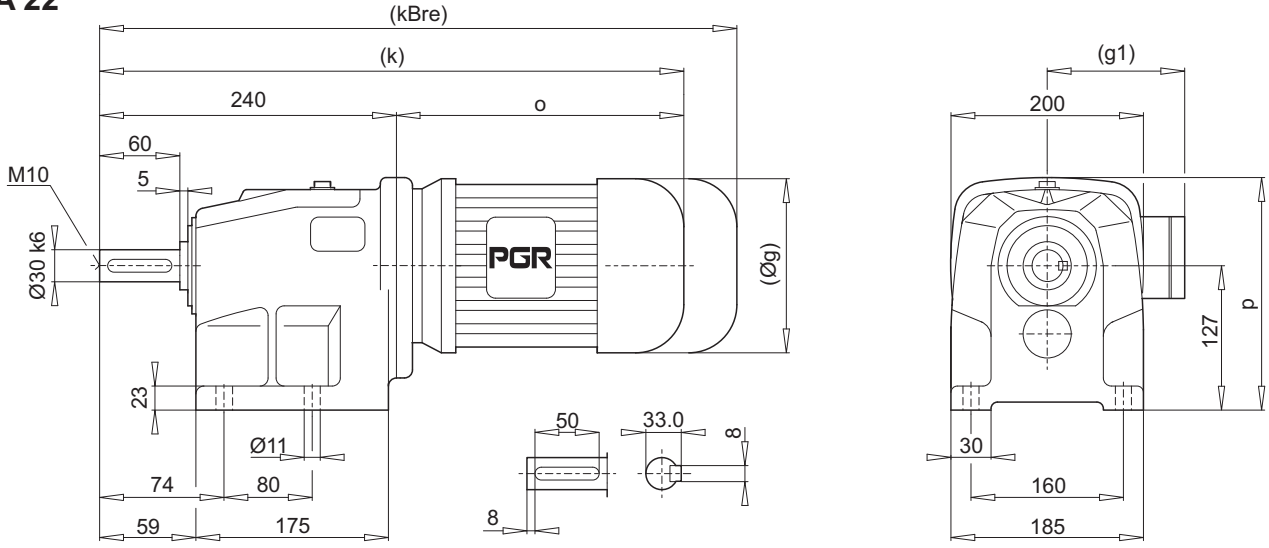

**PF 22**

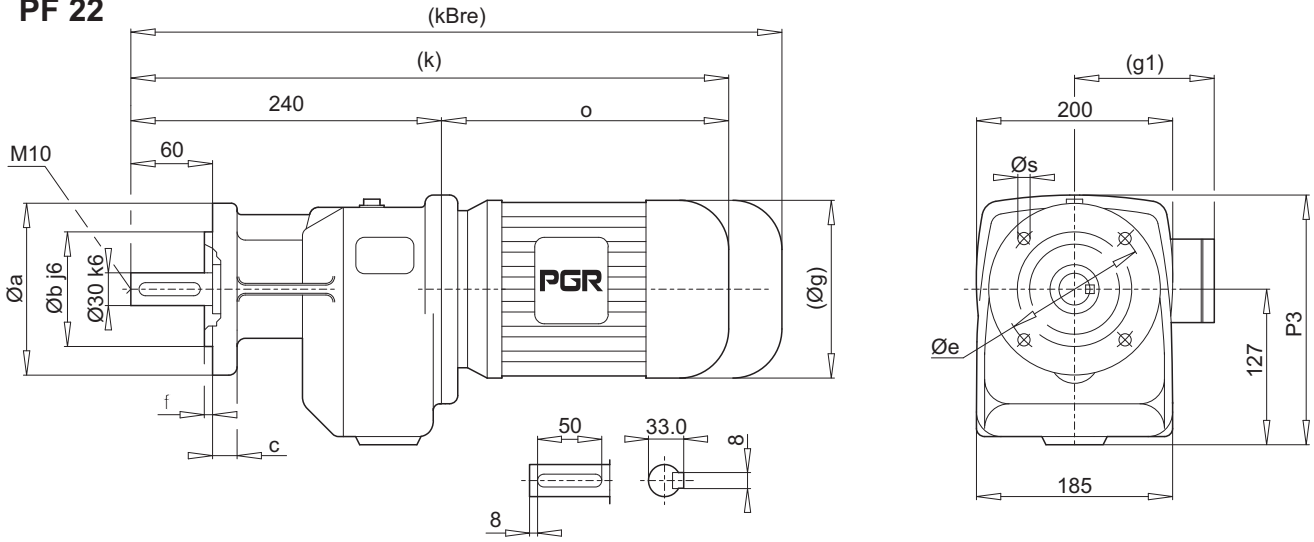

a	b	c	e	f	s
160	110	13	130	3.5	9
200	130	14	165	3.5	11

	71 M	80 M	90 S/L	100 L	112 M			
g	140	159	193	217	232			
g1	119	127	151	160	168			
k	476	502	525/545	573	618			
kBre	536	564	598/618	654	698			
o	236	262	285/305	333	378			
p	226	226	226	228	240			
p3	226	226	226	228	240			

**Not : (...)** İşaretili olan ölçüler Motor markasına göre farklılık gösterir.  
Note : Dimension which is designated by (...) depends on marks of motor.

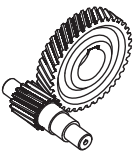

**PA 23**

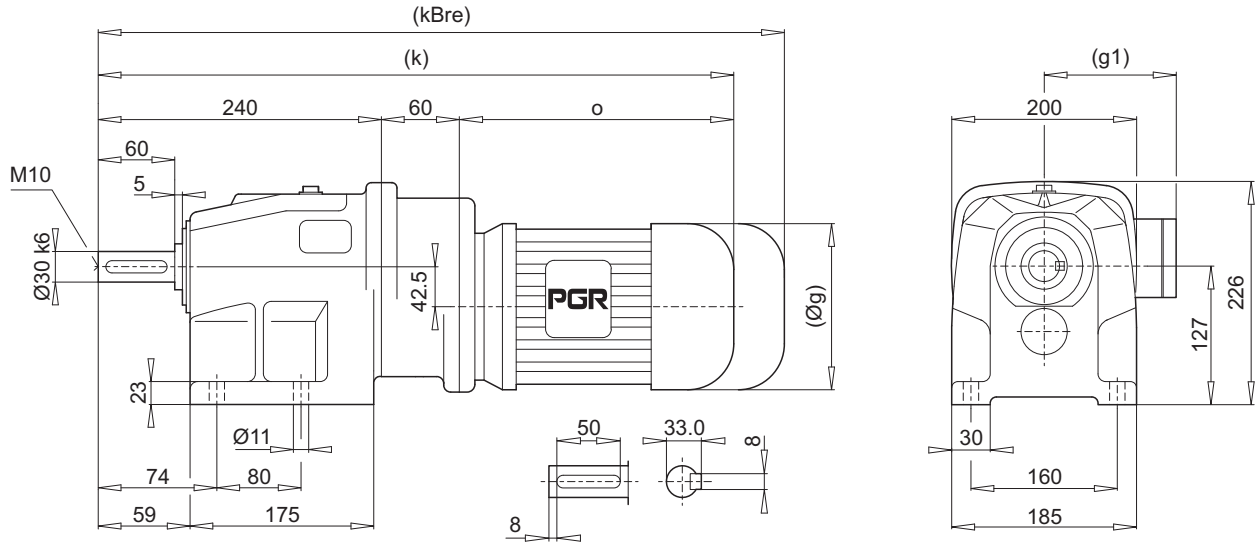

**PF 23**

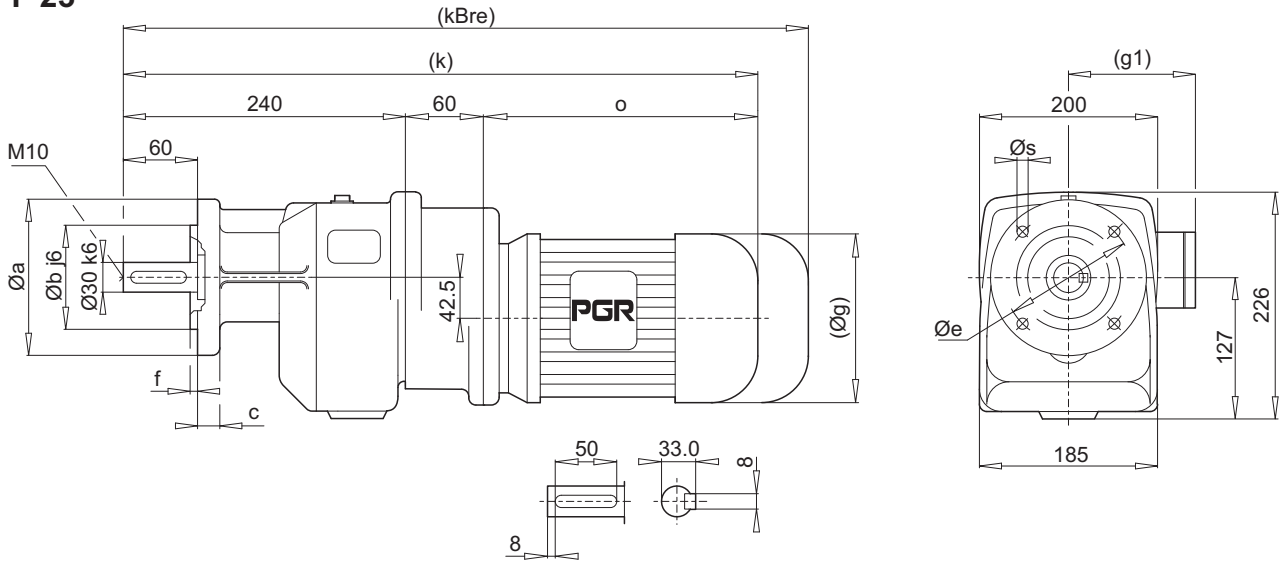

a	b	c	e	f	s
160	110	13	130	3.5	9
200	130	14	165	3.5	11

	63 M	71 M	80 M				
g	124	140	159				
g1	111	119	127				
k	498	540	567				
kBre	550	600	629				
o	198	240	267				

**Not : (...)** İşaretili olan ölçüler Motor markasına göre farklılık gösterir.  
Note : Dimension which is designated by (...) depends on marks of motor.

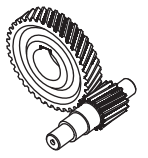

**PA 32**

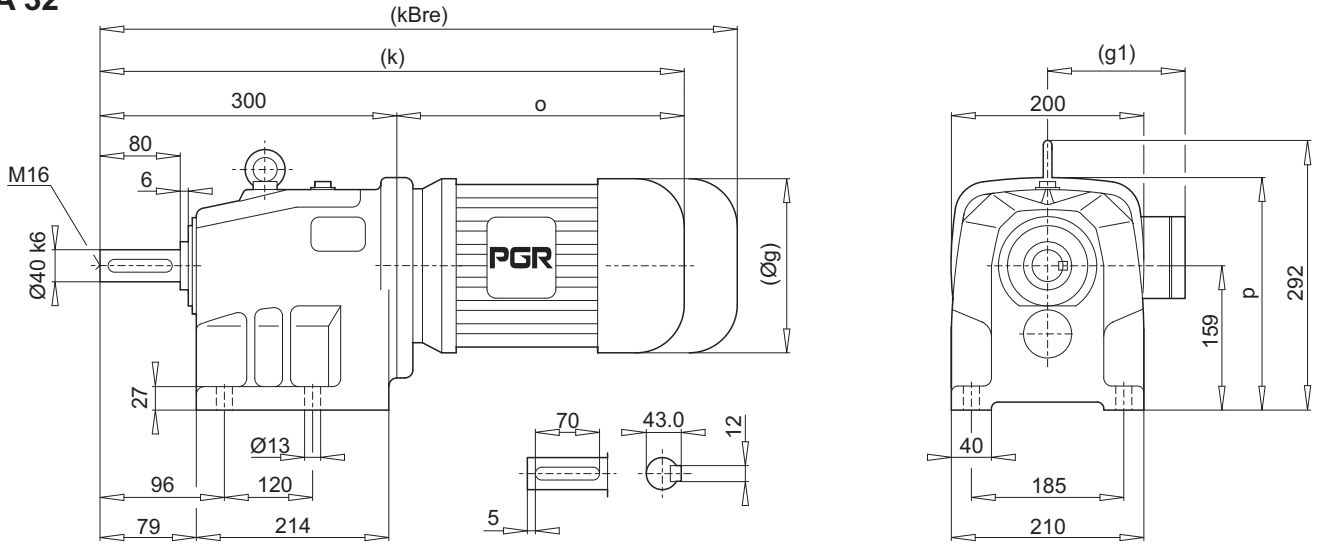

**PF 32**

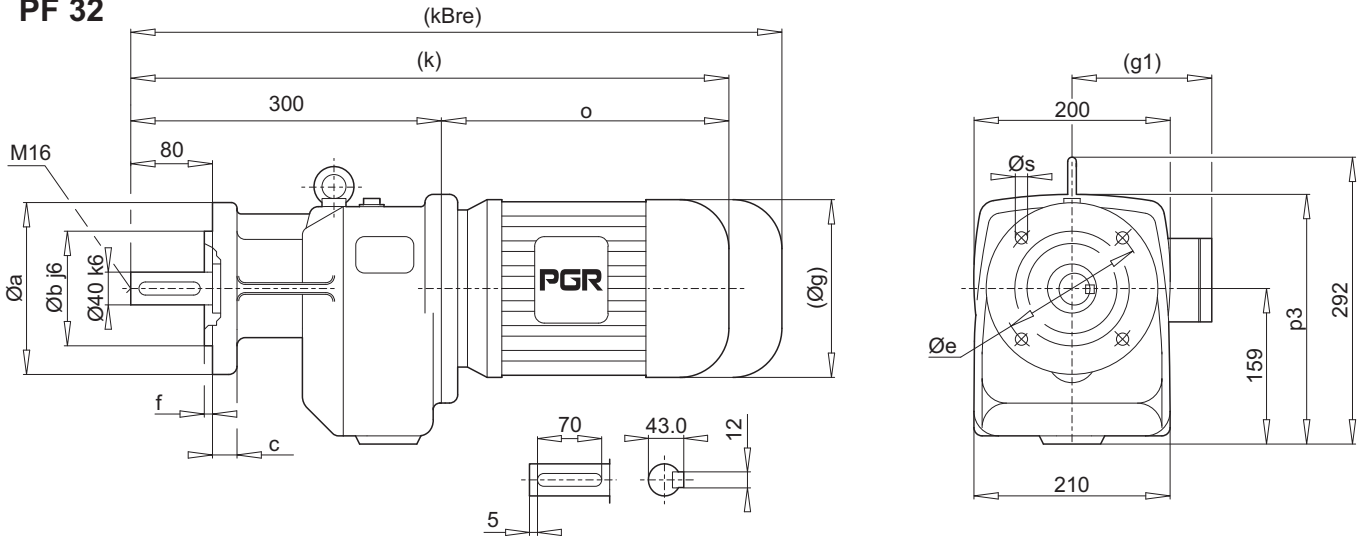

a	b	c	e	f	s
200	130	14	165	3.5	11
250	180	16	215	4.0	14

	71 M	80 M	90 S/L	100 L	112 M	132 S/M		
g	140	159	193	217	232	279		
g1	119	127	151	160	168	182		
k	536	562	585/605	633	678	685/720		
kBre	596	624	658/678	714	758	793/828		
o	236	262	285/305	333	378	385/420		
p	260	260	260	260	271	290		
p3	260	260	260	260	271	290		

**Not : (...)** İşaretili olan ölçüler Motor markasına göre farklılık gösterir.  
Note : Dimension which is designated by (...) depends on marks of motor.

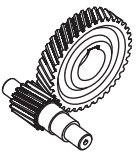

**PA 33**

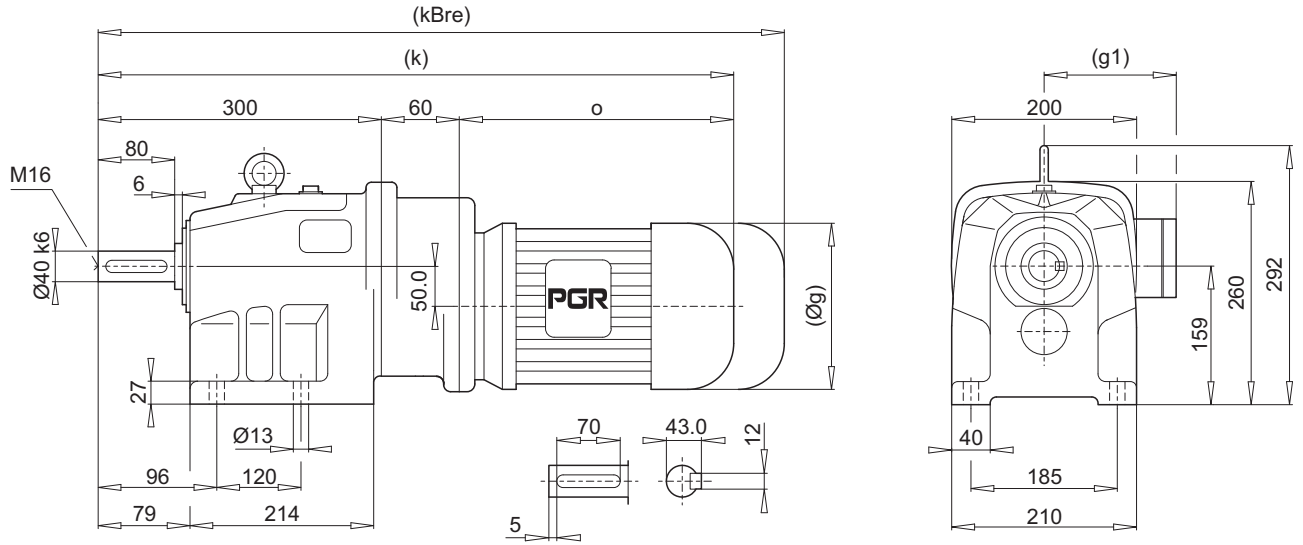

**PF 33**

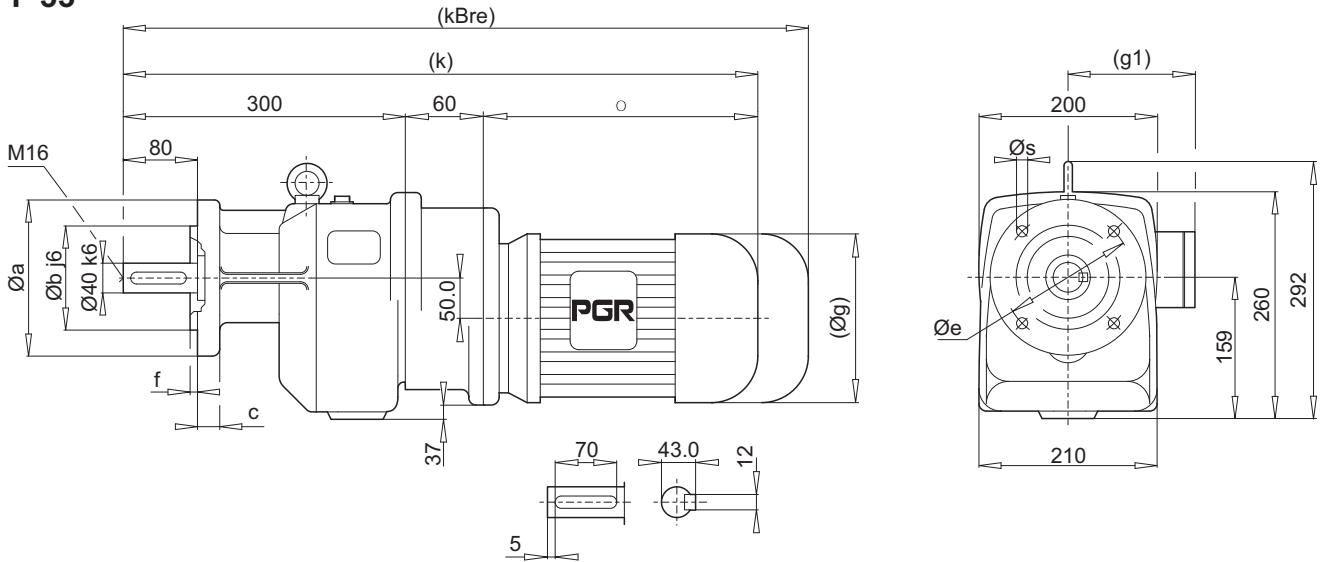

a	b	c	e	f	s
200	130	14	165	3.5	11
250	180	16	215	4.0	14

	63 M	71 M	80 M				
g	124	140	159				
g1	111	119	127				
k	558	600	627				
kBre	610	660	689				
o	198	240	267				

**Not : (...)** İşaretili olan ölçüler Motor markasına göre farklılık gösterir.  
Note : Dimension which is designated by (...) depends on marks of motor.

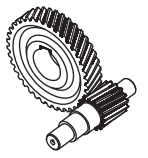

**PA 42**

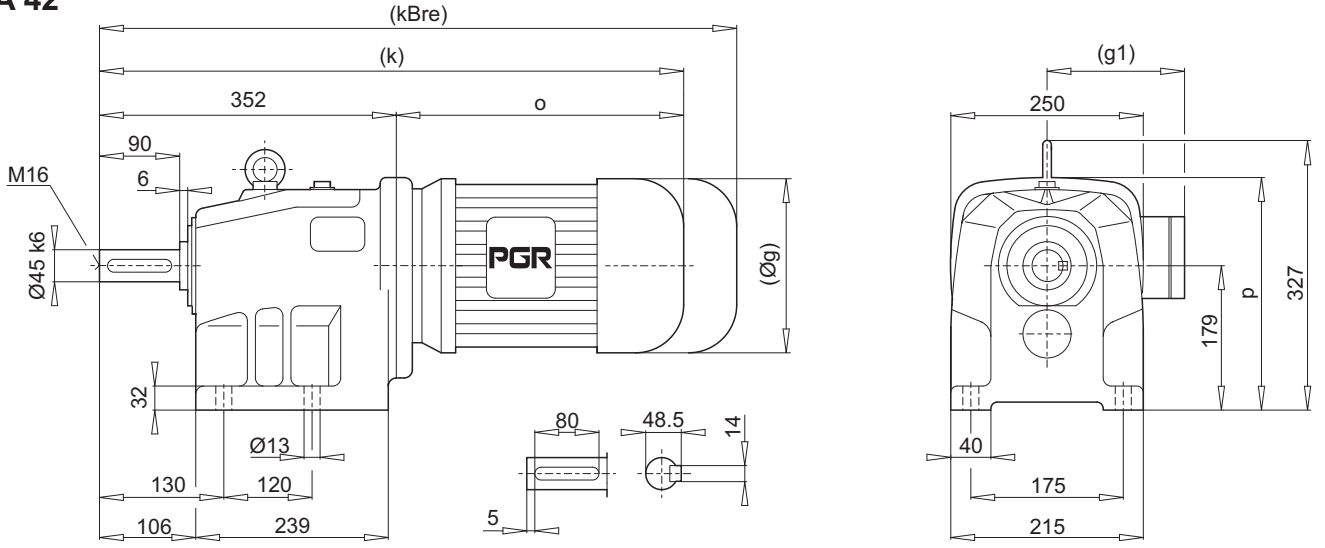

**PF 42**

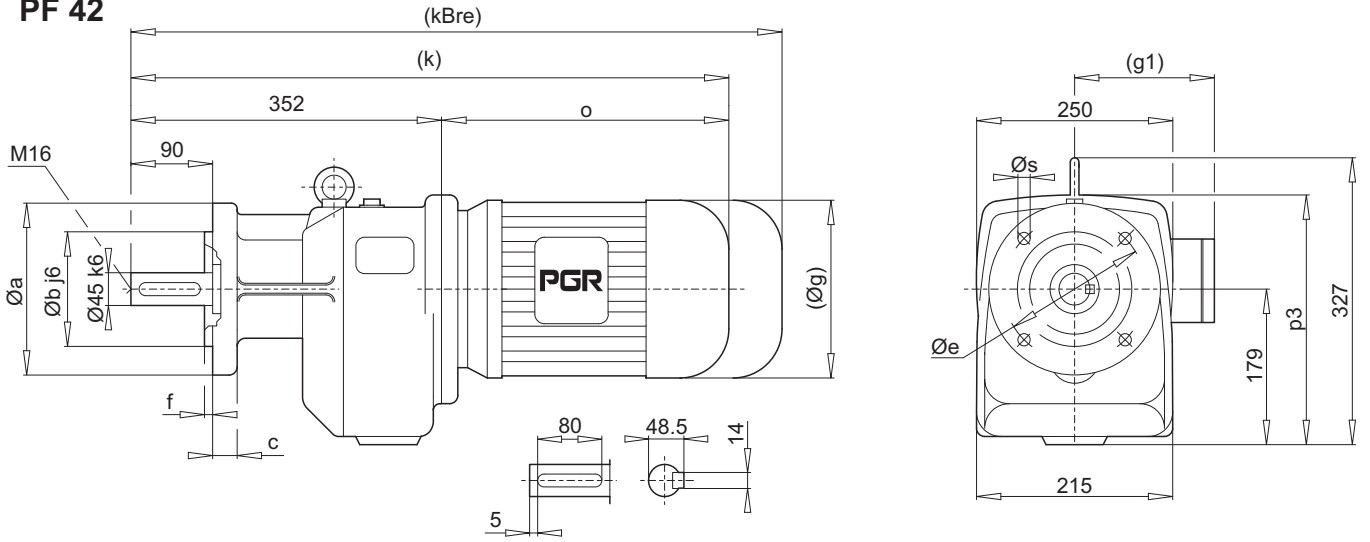

a	b	c	e	f	s
200	130	14	165	3.5	11
250	180	16	215	4.0	14

	90 S/L	100 L	112 M	132 S/M	160 M/L			
g	193	217	232	279	323			
g1	151	160	168	182	200			
k	617/637	665	710	717/752	872			
kBre	690/710	746	790	825/860	1024			
o	265/285	313	358	365/400	520			
p	302	302	302	310	337			
p3	302	302	302	310	337			

**Not : (...)** İşaretili olan ölçüler Motor markasına göre farklılık gösterir.  
Note : Dimension which is designated by (...) depends on marks of motor.

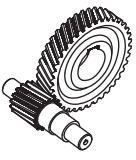

**PA 43**

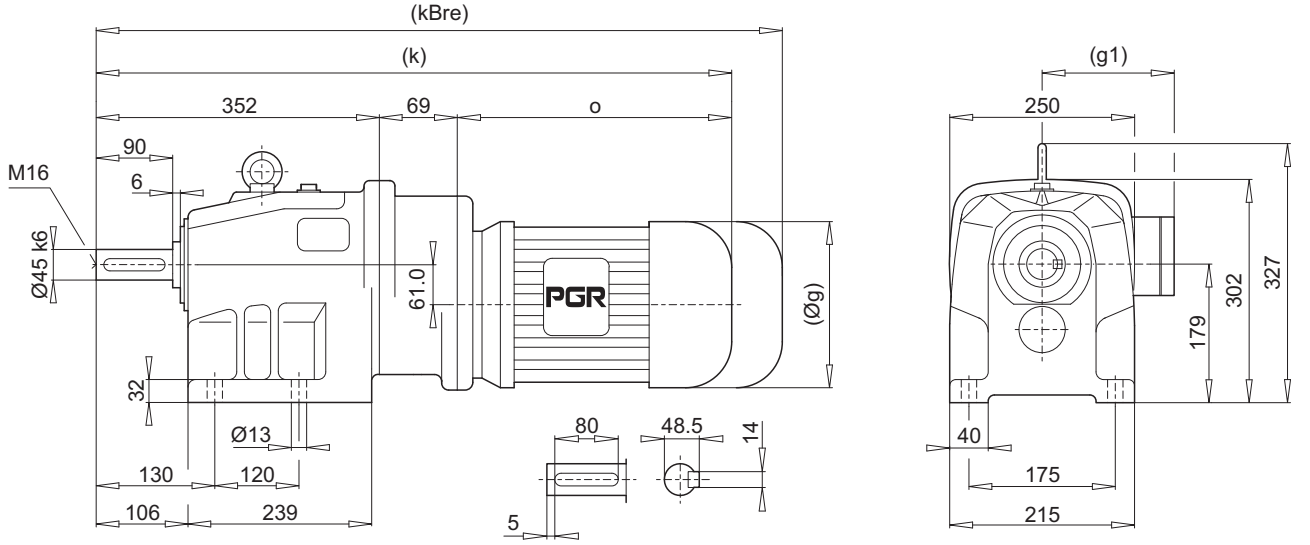

**PF 43**

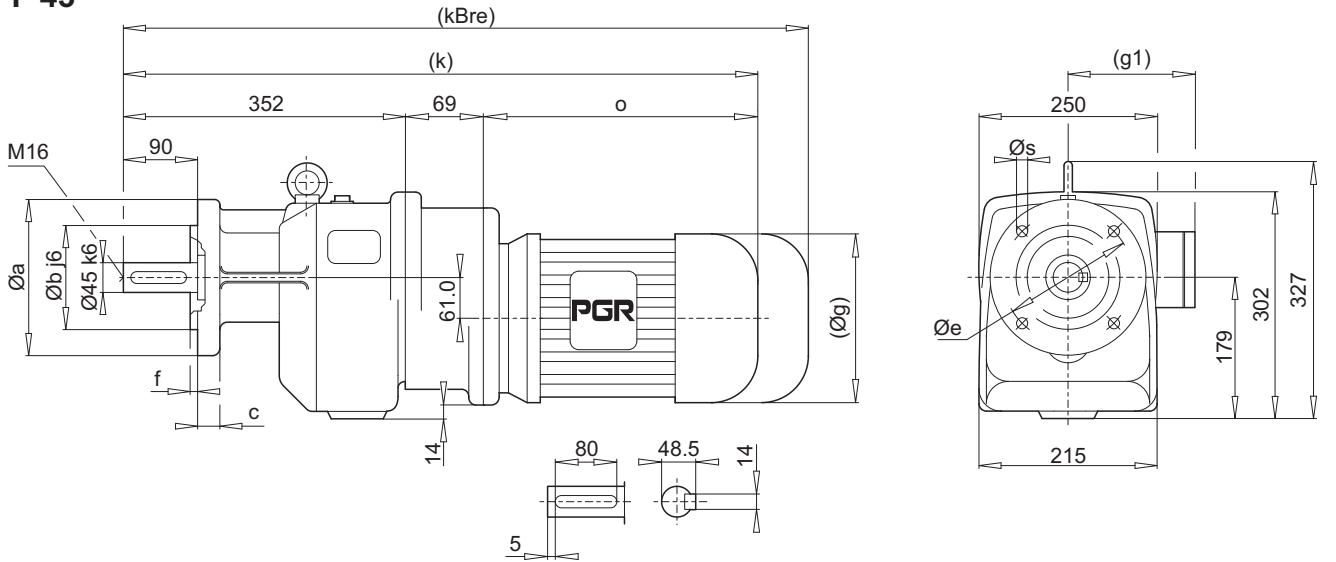

a	b	c	e	f	s
200	130	14	165	3.5	11
250	180	16	215	4.0	14

	71 M	80 M	90 S/L	100 L	112 M			
g	140	159	193	217	232			
g1	119	127	151	160	168			
k	657	683	706/726	754	799			
kBre	717	745	779/799	835	879			
o	236	262	285/305	333	378			

**Not : (...)** İşaretili olan ölçüler Motor markasına göre farklılık gösterir.  
Note : Dimension which is designated by (...) depends on marks of motor.

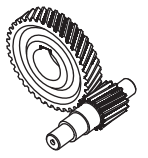

**PA 52**

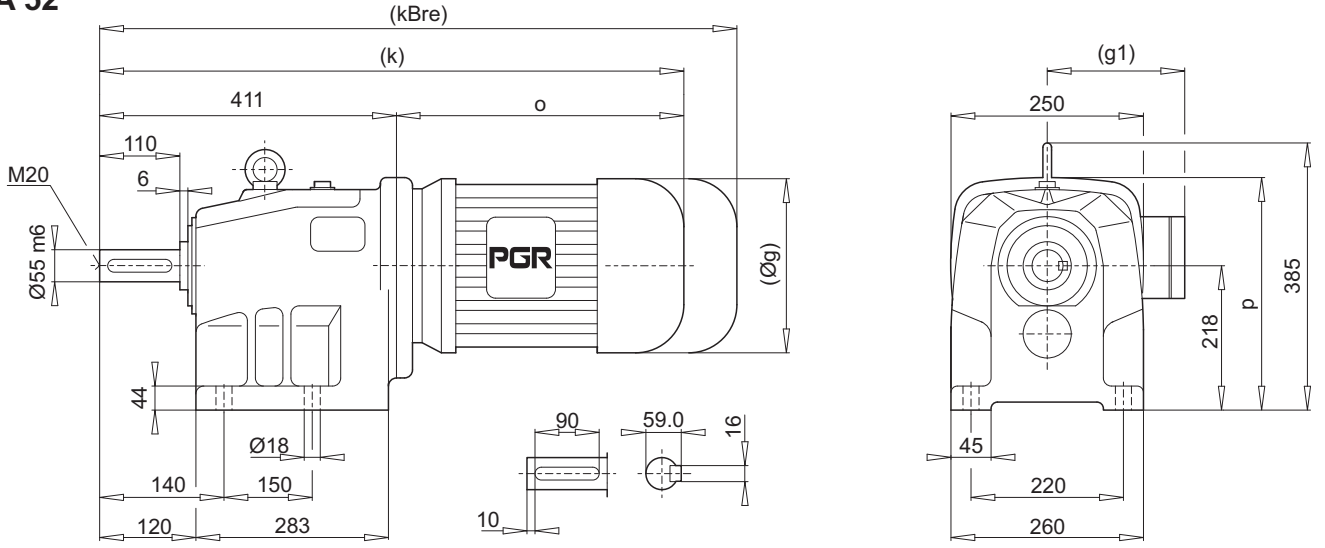

**PF 52**

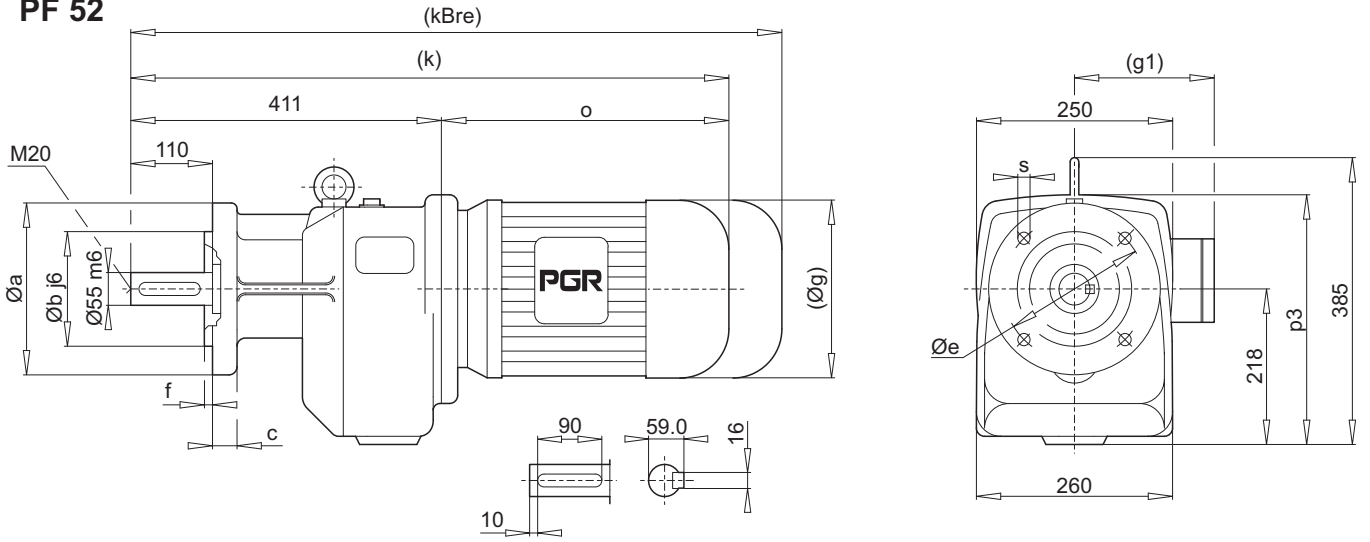

a	b	c	e	f	s
250	180	16	215	4.0	14
300	230	20	265	4.0	14

	90 S/L	100 L	112 M	132 S/M	160 M/L	180 M/L		
g	193	217	232	279	323	370		
g1	151	160	168	182	200	248		
k	676/696	724	769	776/811	931	990		
kBre	749/769	805	849	884/919	1083	1152		
o	265/285	313	358	365/400	520	579		
p	339	339	339	347	374	374		
p3	339	339	339	347	374	374		

**Not : (...)** İşaretili olan ölçüler Motor markasına göre farklılık gösterir.  
Note : Dimension which is designated by (...) depend on marks of motor.

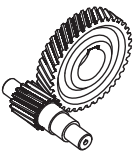

**PA 53**

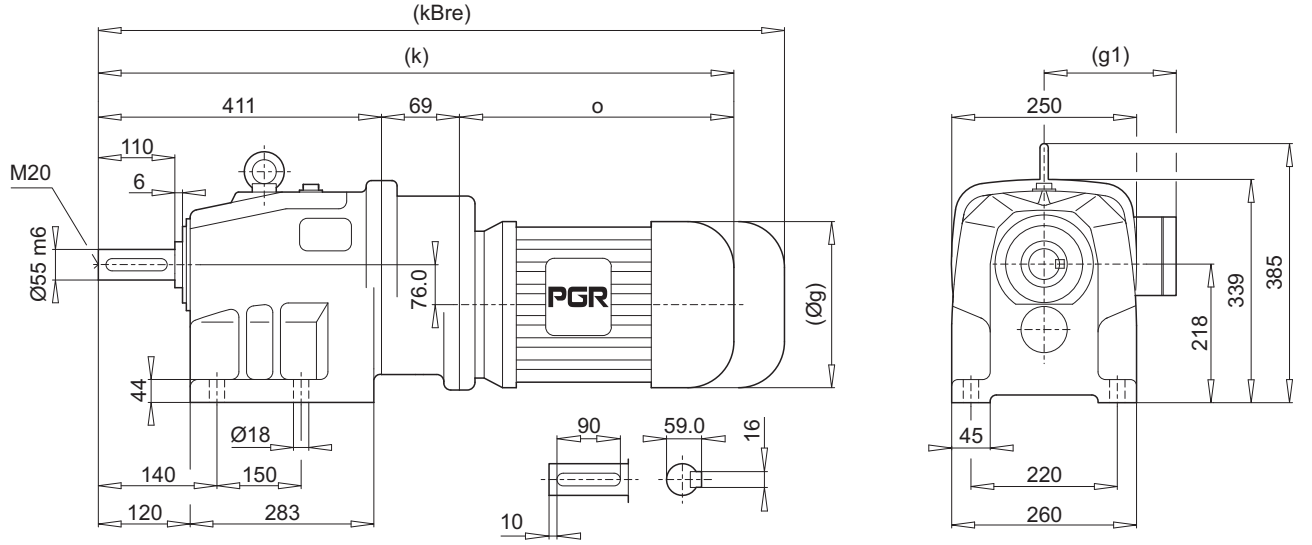

**PF 53**

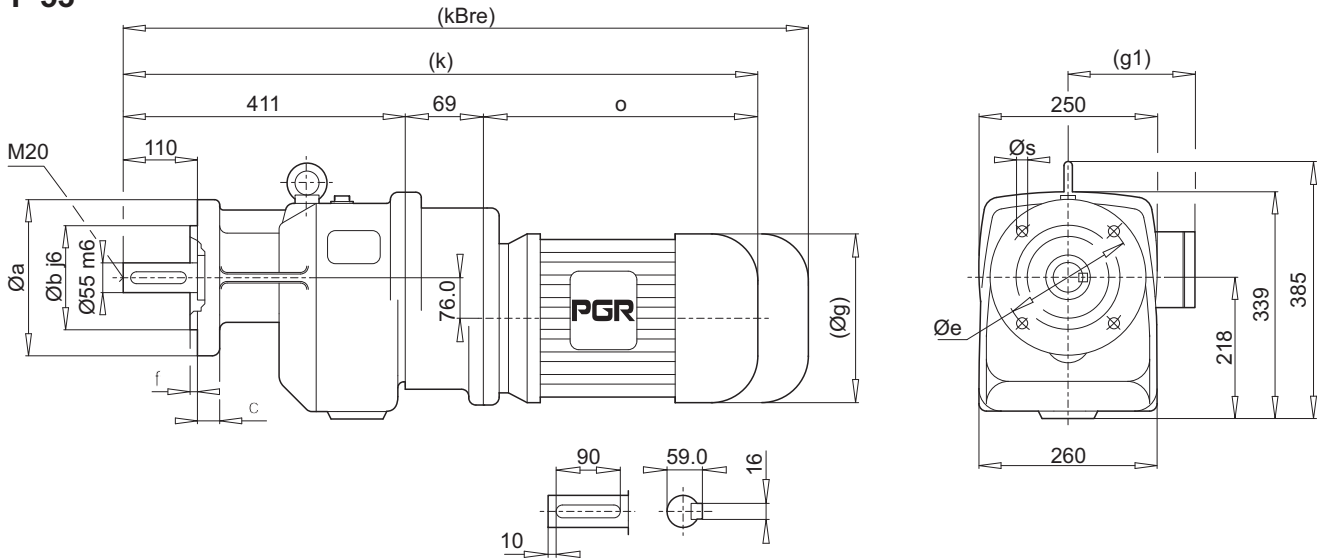

a	b	c	e	f	s
250	180	16	215	4.0	14
300	230	20	265	4.0	14

	71 M	80 M	90 S/L	100 L	112 M			
g	140	159	193	217	232			
g1	119	127	151	160	168			
k	716	742	765/785	813	858			
kBre	776	804	838/858	894	938			
o	236	262	285/305	333	378			

**Not : (...)** İşaretili olan ölçüler Motor markasına göre farklılık gösterir.  
Note : Dimension which is designated by (...) depends on marks of motor.

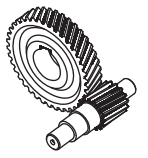

**PA 62**

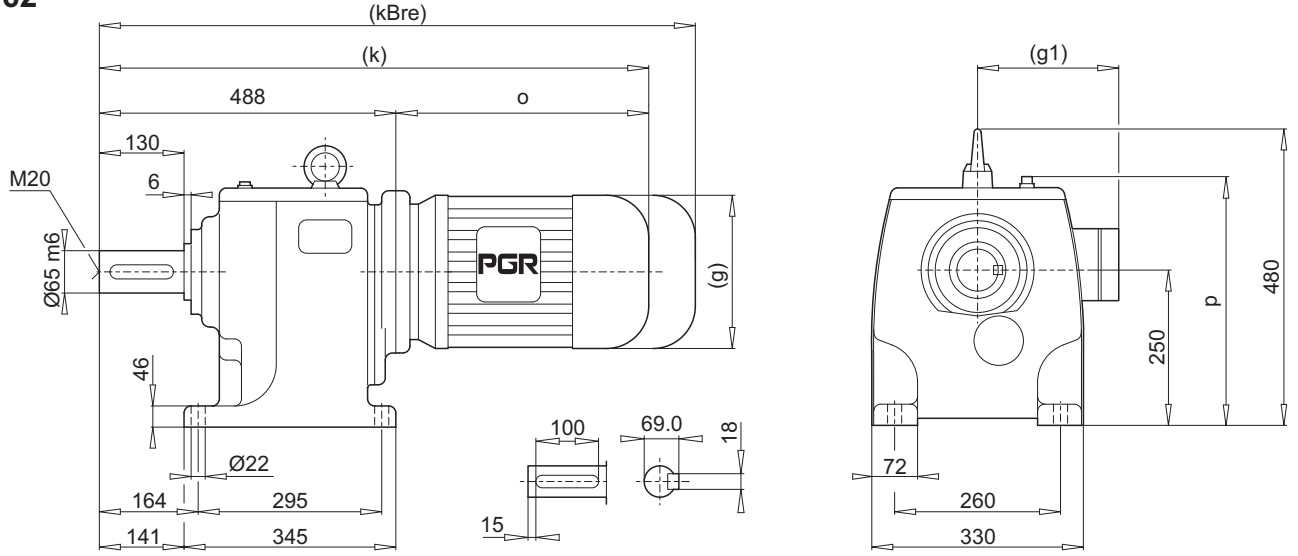

**PF 62**

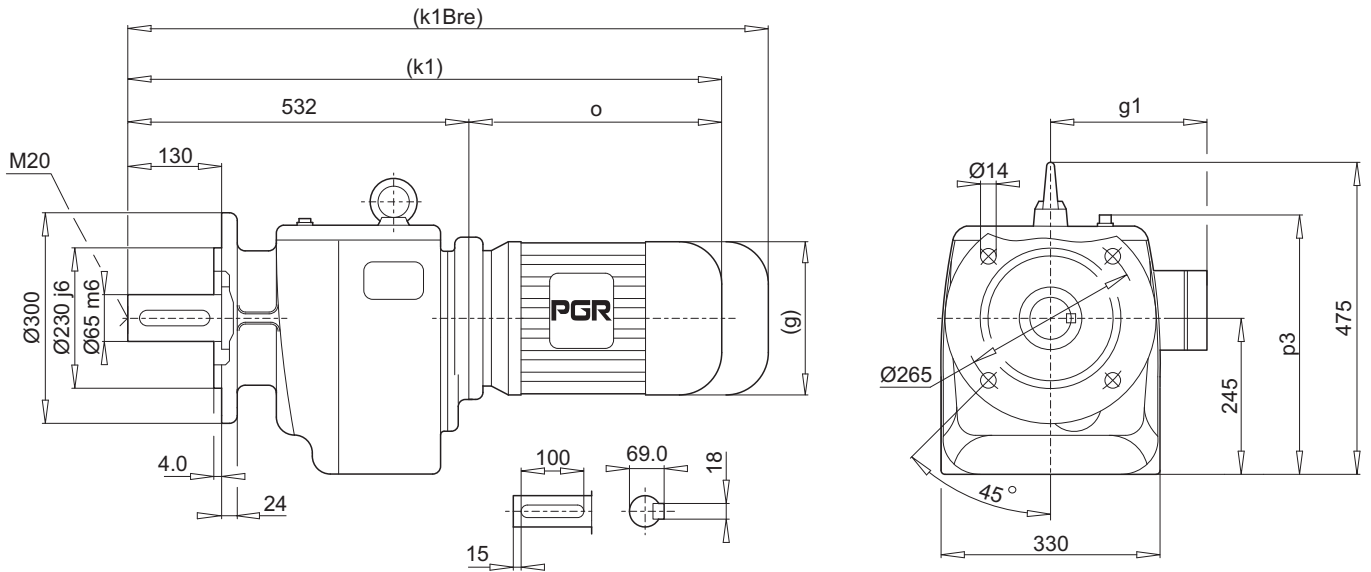

	112 M	132 S/M	160 M/L	180 M/L	200 L	225 S/M		
g	232	279	323	370	415	456		
g1	168	182	200	248	260	260		
k	845	901	971	1011	1180	1180		
kBre	925	1009	1123	1173	1327	1352		
k1	889	945	1015	1055	1224	1224		
k1Bre	969	1053	1167	1217	1371	1396		
o	357	413	483	523	692	692		
p	400	400	425	425	449	485		
p3	395	395	420	420	449	485		

**Not : (...)** İşaretili olan ölçüler Motor markasına göre farklılık gösterir.  
Note : Dimension which is designated by (...) depends on marks of motor.

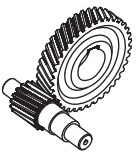

**PA 63**

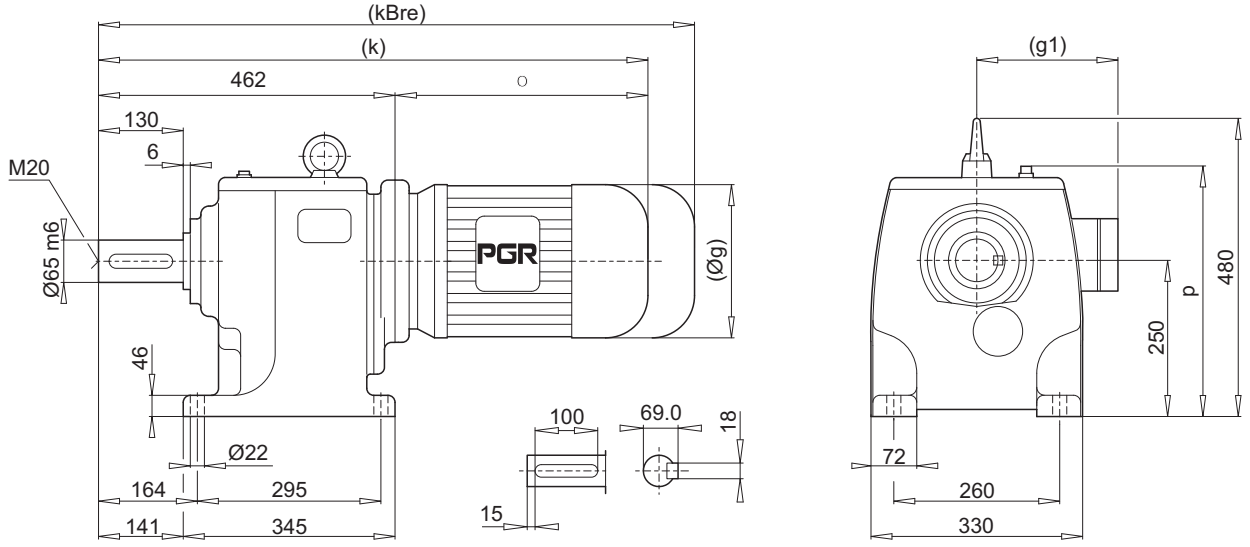

**PF 63**

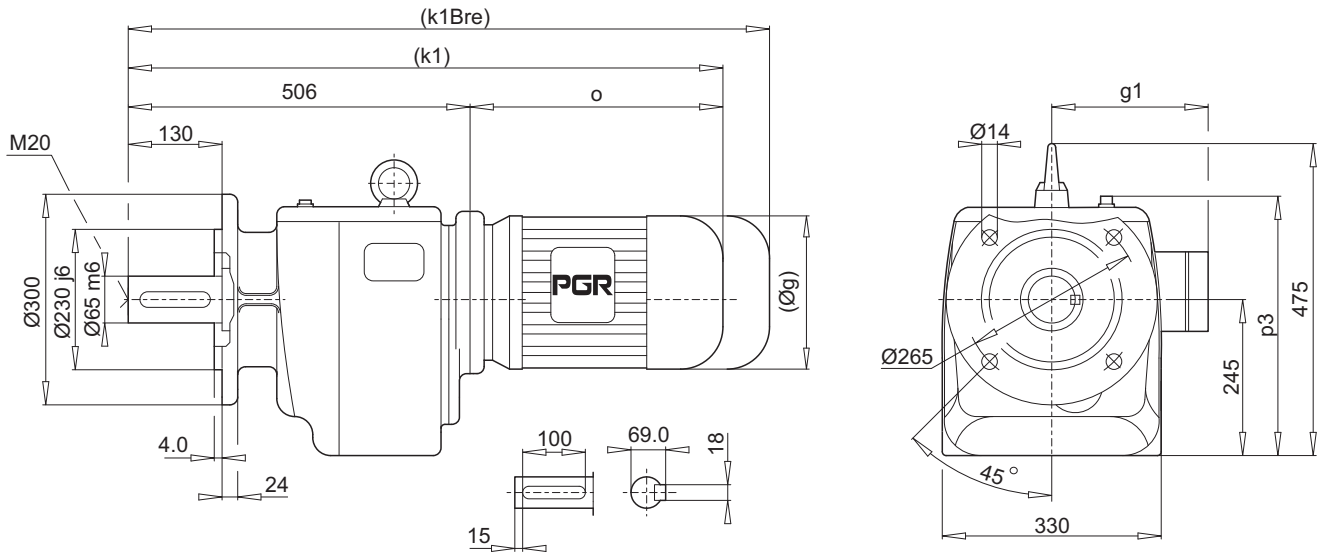

	90 S/L	100 L	112 M	132 S/M	160 M/L	180 M/L		
g	193	217	232	279	323	370		
g1	151	160	168	182	200	248		
k	727/747	775	820	827/862	982	1041		
kBre	800/820	856	900	935/970	1134	1203		
k1	771/791	819	864	871/906	1026	1085		
k1Bre	844/864	900	944	979/1014	1178	1247		
o	265/285	313	358	365/400	520	579		
p	400	400	400	400	410	410		
p3	395	395	395	395	405	405		

**Not : (...)** İşaretili olan ölçüler Motor markasına göre farklılık gösterir.  
Note : Dimension which is designated by (...) depends on marks of motor.



**PA 72**

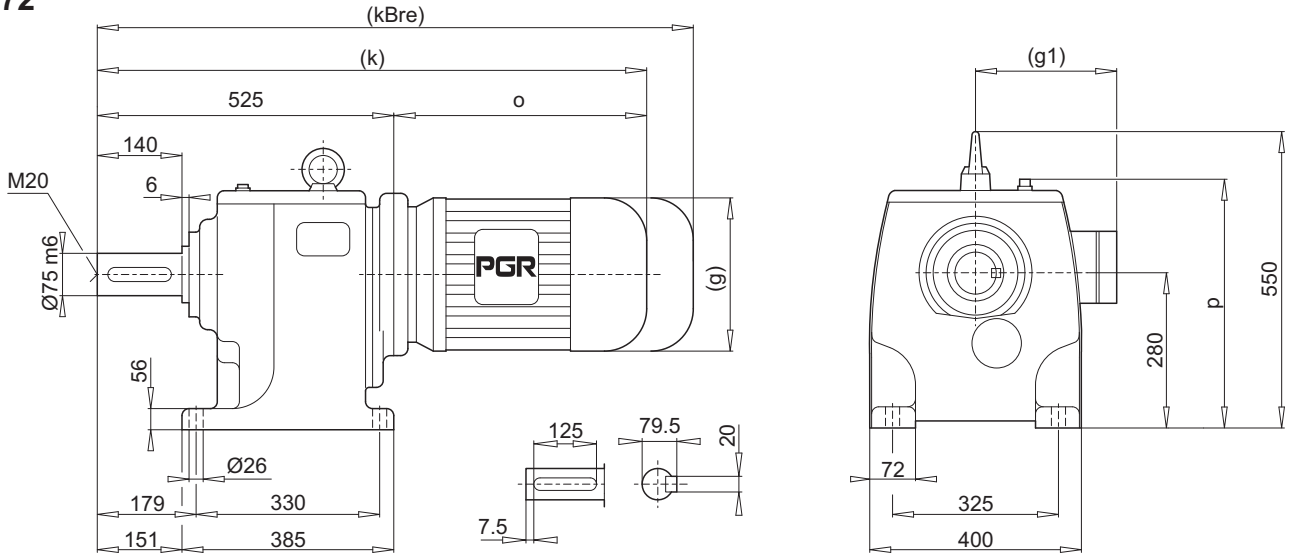

**PF 72**

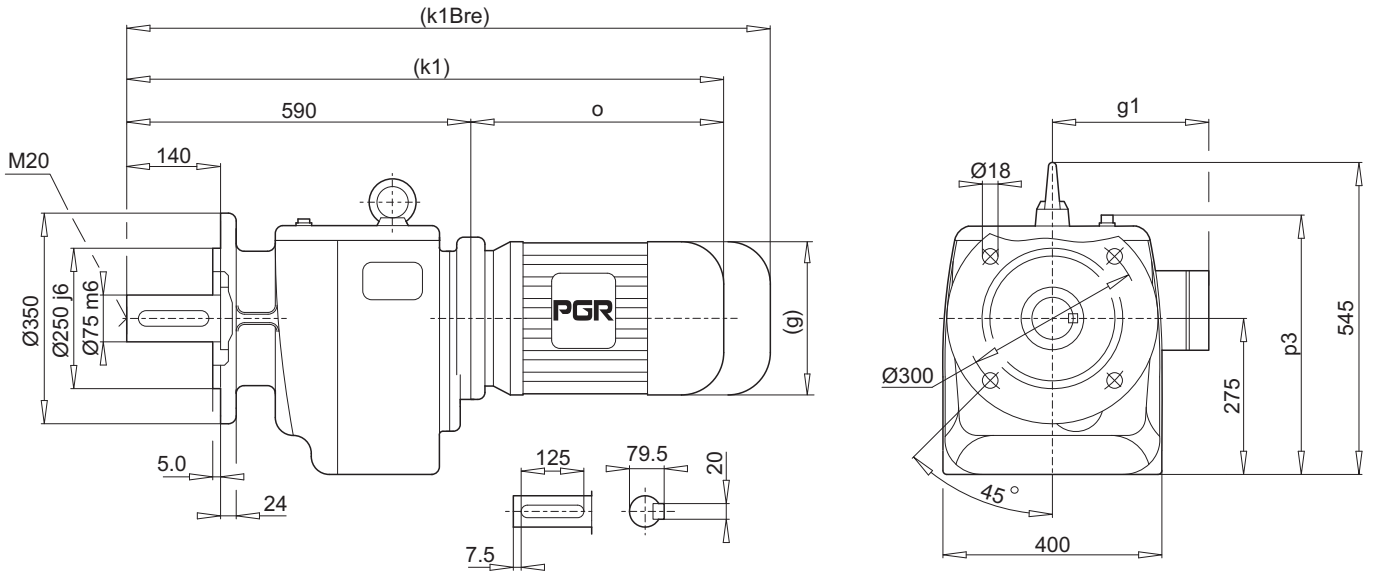

	132 S/M	160 M/L	180 M/L	200 L	225 S/M			
g	279	323	370	415	456			
g1	182	200	248	260	260			
k	938	1008	1048	1217	1217			
kBre	1046	1160	1210	1364	1389			
k1	1003	1073	1113	1282	1282			
k1Bre	1111	1225	1275	1429	1454			
o	413	483	523	692	692			
p	447	455	459	479	479			
p3	442	450	450	479	479			

**Not** : (...) İşaretili olan ölçüler Motor markasına göre farklılık gösterir.  
Note : Dimension which is designated by (...) depends on marks of motor.

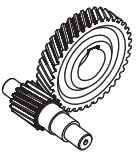

**PA 73**

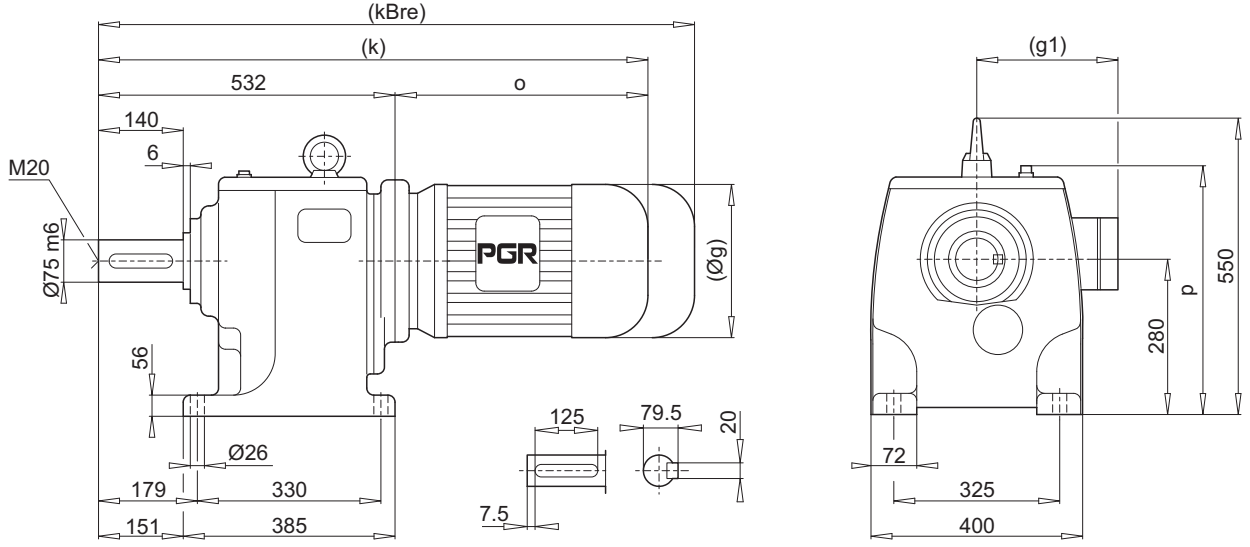

**PF 73**

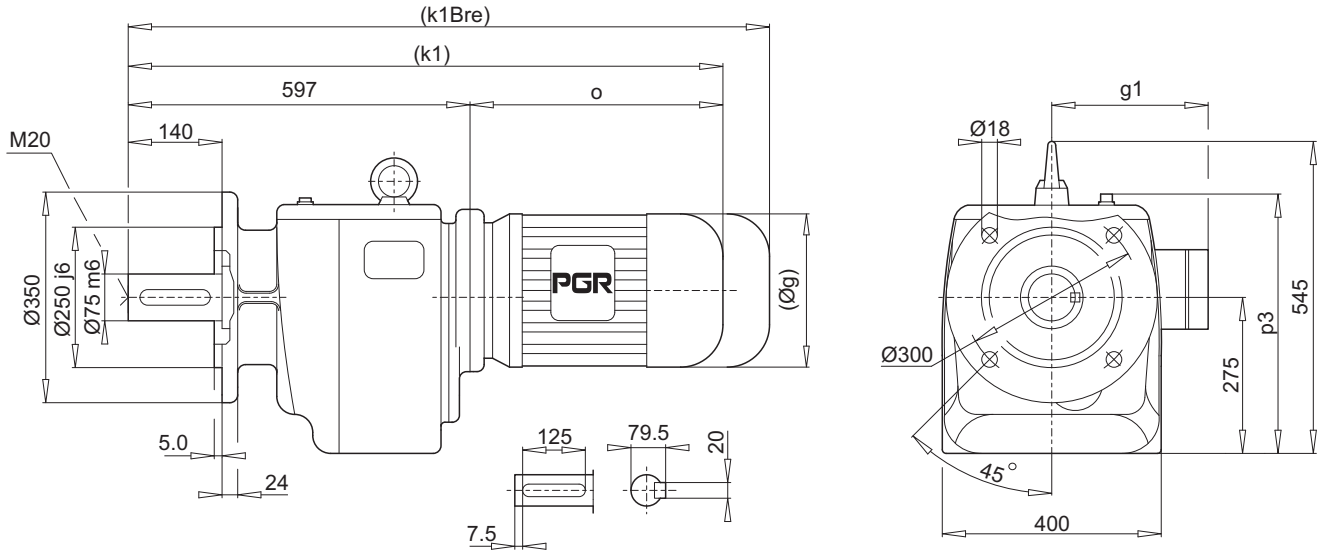

	100 L	112 M	132 S/M	160 M/L	180 M/L	200 L	225 S/M	
g	217	232	279	323	370	415	456	
g1	160	168	182	200	248	260	260	
k	861	889	945	1015	1055	1224	1224	
kBre	942	969	1053	1167	1217	1371	1396	
k1	926	954	1010	1080	1120	1289	1289	
k1Bre	1007	1034	1118	1232	1282	1436	1461	
o	329	357	413	483	523	692	692	
p	447	447	447	455	455	479	479	
p3	442	442	442	450	450	474	474	

**Not** : (...) İşaretili olan ölçüler Motor markasına göre farklılık gösterir.  
Note : Dimension which is designated by (...) depends on marks of motor.

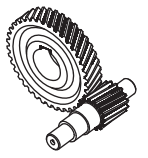

**PA 82**

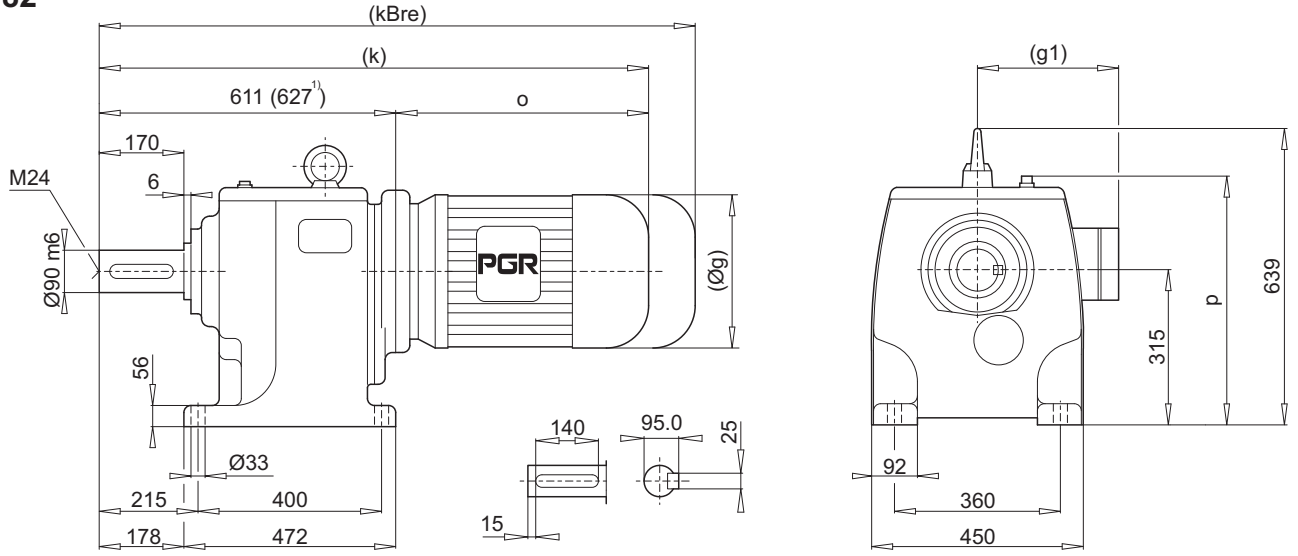

**PF 82**

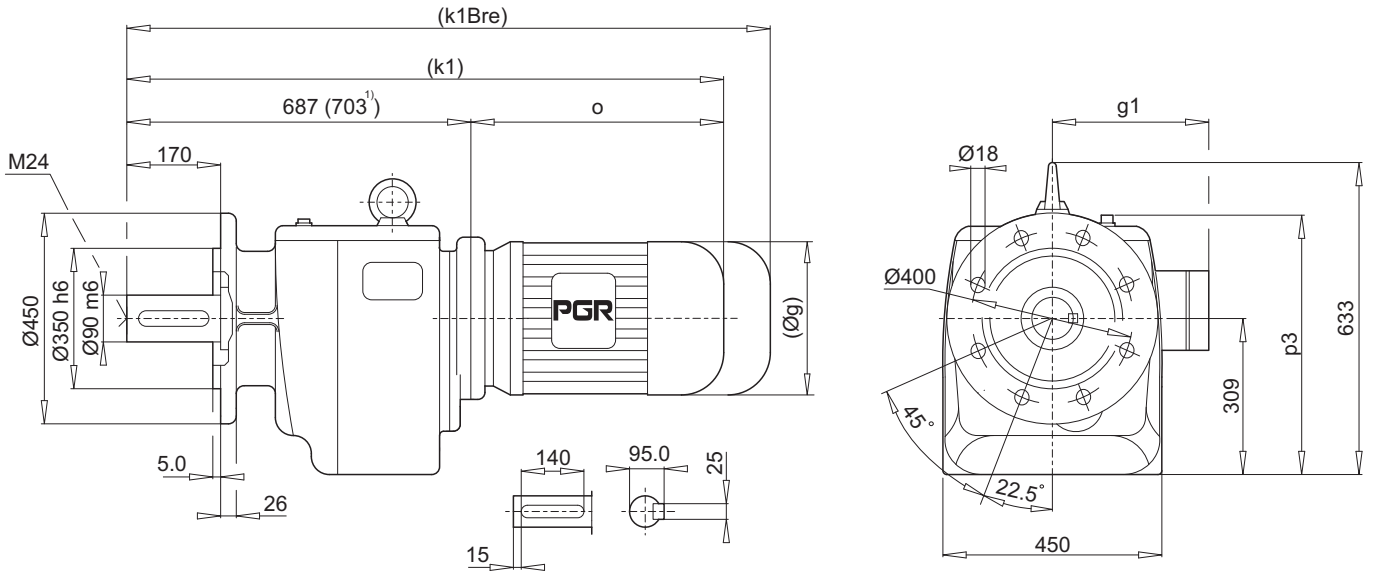

	132 S/M	160 M/L	180 M/L	200 L	225 S/M	250 M <sup>1)</sup>	280 S <sup>1)</sup>	
g	279	323	370	415	456	495	-	
g1	182	200	248	260	260	392	-	
k	1024	1094	1134	1303	1303	1422	-	
kBre	1132	1246	1296	1450	1475	1677	-	
k1	1100	1170	1210	1379	1379	1498	-	
k1Bre	1208	1322	1372	1526	1551	1753	-	
o	413	483	523	692	692	795	-	
p	512	512	512	514	514	575	-	
p3	506	506	506	508	508	569	-	

**Not** : (...) İşaretili olan ölçüler Motor markasına göre farklılık gösterir.  
Note : Dimension which is designated by (...) depends on marks of motor.

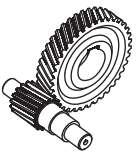

**PA 83**

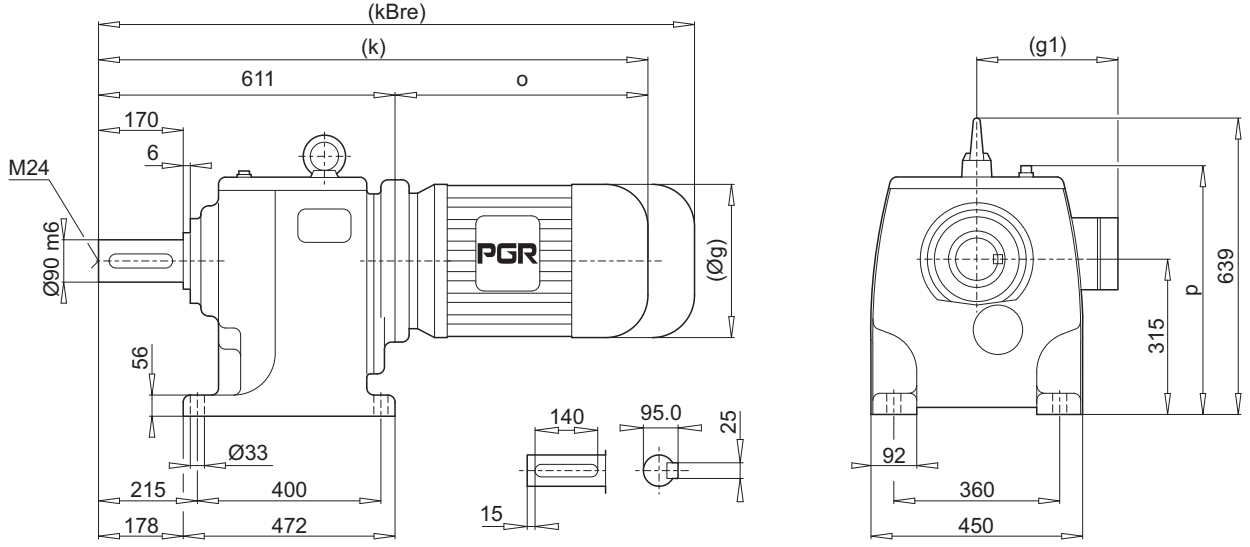

**PF 83**

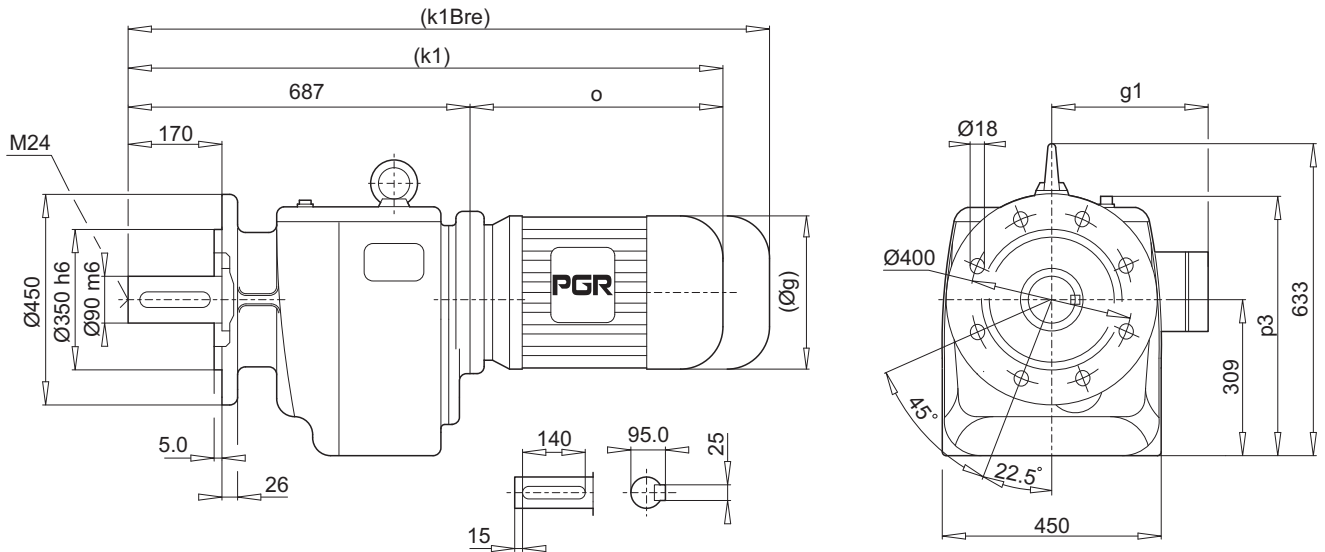

	100 L	112 M	132 S/M	160 M/L	180 M/L	200 L	225 S/M	
g	217	232	279	323	370	415	456	
g1	160	168	182	200	248	260	260	
k	940	968	1024	1094	1134	1303	1303	
kBre	1021	1048	1132	1246	1296	1450	1475	
k1	1016	1044	1100	1170	1210	1379	1379	
k1Bre	1097	1124	1208	1322	1372	1526	1551	
o	329	357	413	483	523	692	692	
p	512	512	512	512	512	514	514	
p3	506	506	506	506	506	508	508	

**Not** : (...) İşaretli olan ölçüler Motor markasına göre farklılık gösterir.  
Note : Dimension which is designated by (...) depends on marks of motor.

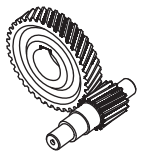

**PA 92**

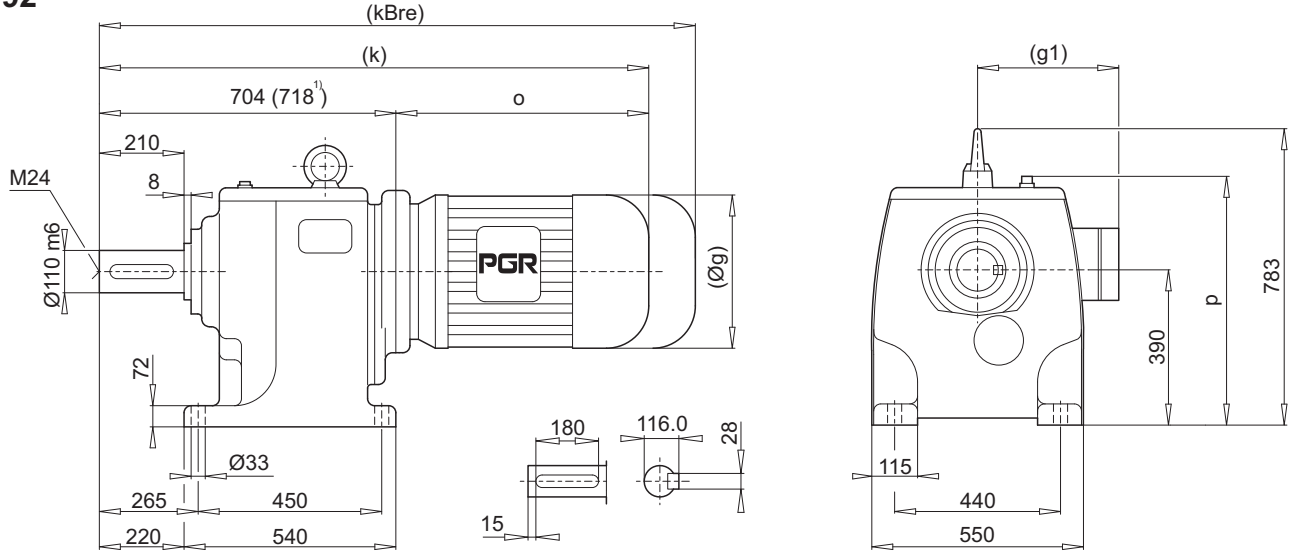

**PF 92**

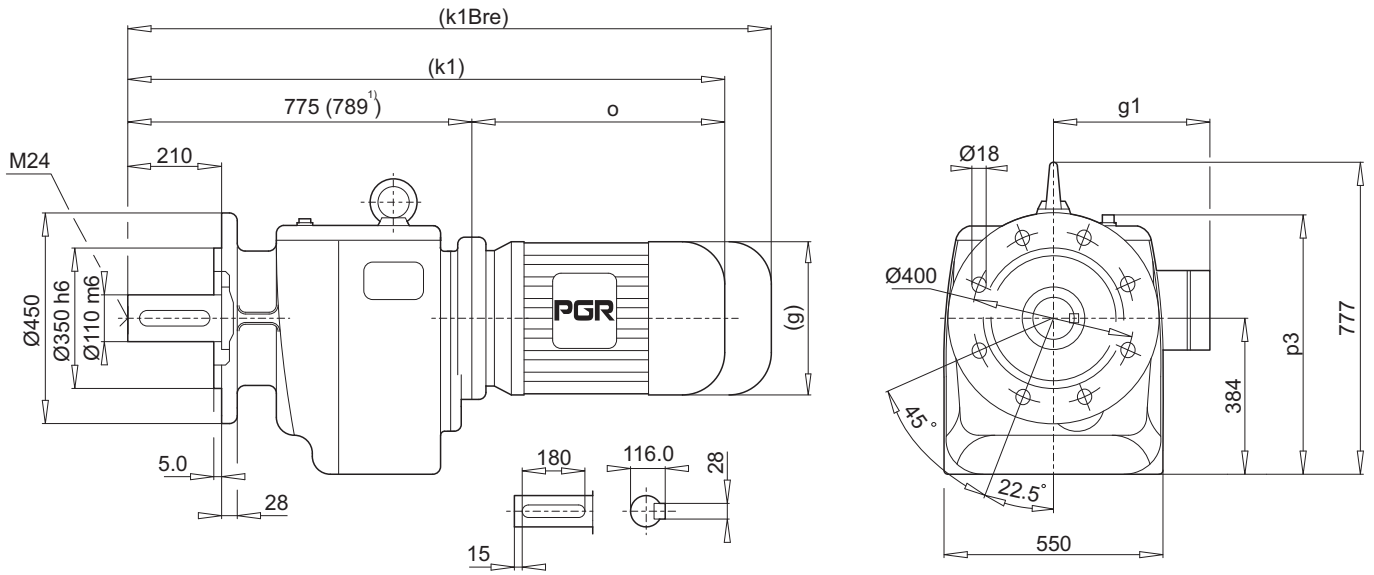

	180 M/L	200 L	225 S/M	250 M <sup>1)</sup>	280 S <sup>1)</sup>	280 M <sup>1)</sup>	315 S <sup>1)</sup>	315 M <sup>1)</sup>
g	370	415	456	495	-	-	-	-
g1	248	260	260	392	-	-	-	-
k	1227	1396	1396	1513	-	-	-	-
kBre	1389	1543	1568	1768	-	-	-	-
k1	1298	1467	1467	1584	-	-	-	-
k1Bre	1460	1614	1639	1839	-	-	-	-
o	523	692	692	795	-	-	-	-
p	622	622	622	650	-	-	-	-
p3	616	616	616	644	-	-	-	-

**Not** : (...) İşaretili olan ölçüler Motor markasına göre farklılık gösterir.  
Note : Dimension which is designated by (...) depends on marks of motor.

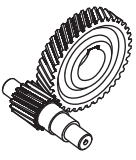

**PA 93**

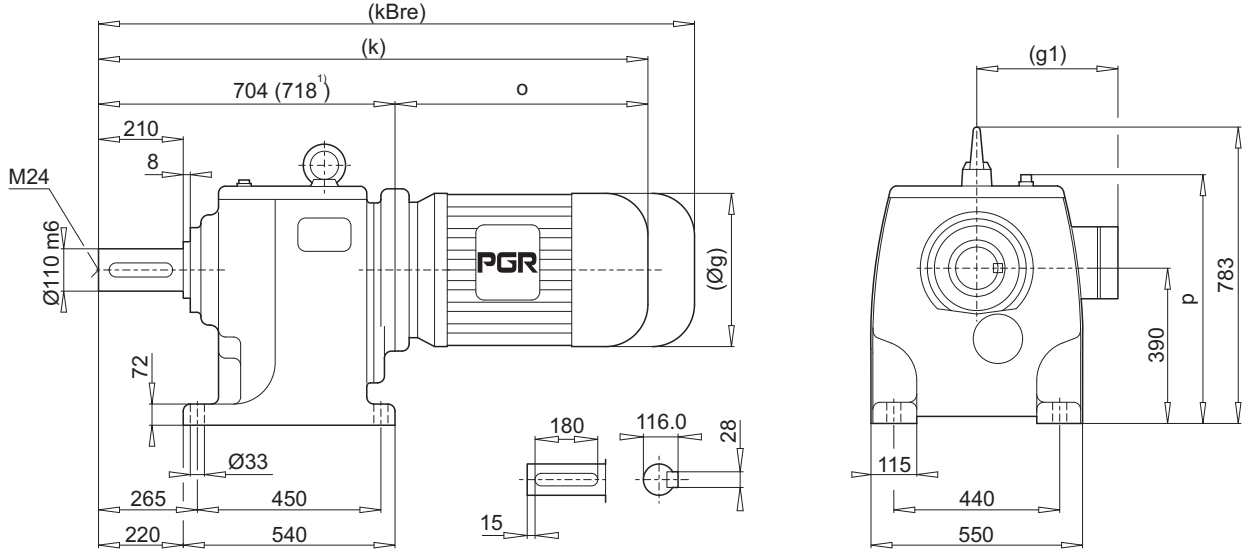

**PF 93**

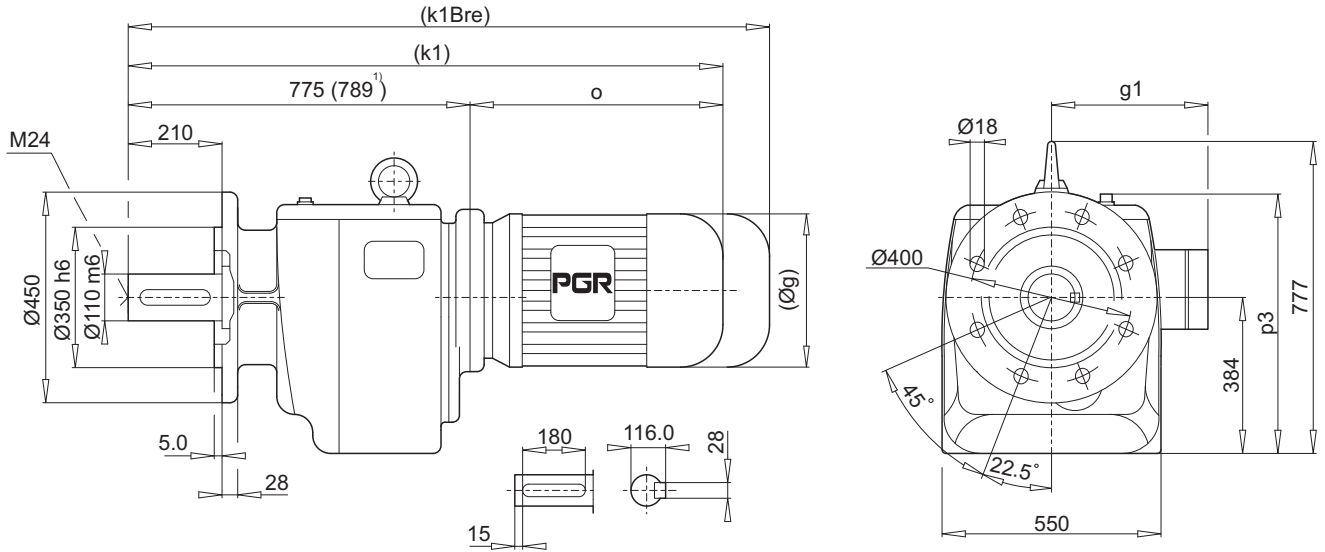

	132 S/M	160 M/L	180 M/L	200 L	225 S/M	250 M <sup>1)</sup>	280 S <sup>1)</sup>	
g	279	323	370	415	456	495	-	
g1	182	200	248	260	260	392	-	
k	1117	1187	1227	1396	1396	1513	-	
kBre	1225	1339	1389	1543	1568	1768	-	
k1	1188	1258	1298	1467	1467	1584	-	
k1Bre	1296	1410	1460	1614	1639	1839	-	
o	413	483	523	692	692	795	-	
p	622	622	622	622	622	650	-	
p3	616	616	616	616	616	644	-	

**Not** : (...) İşaretili olan ölçüler Motor markasına göre farklılık gösterir.  
Note : Dimension which is designated by (...) depends on marks of motor.

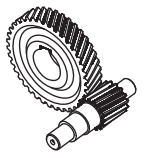

**PA 102**

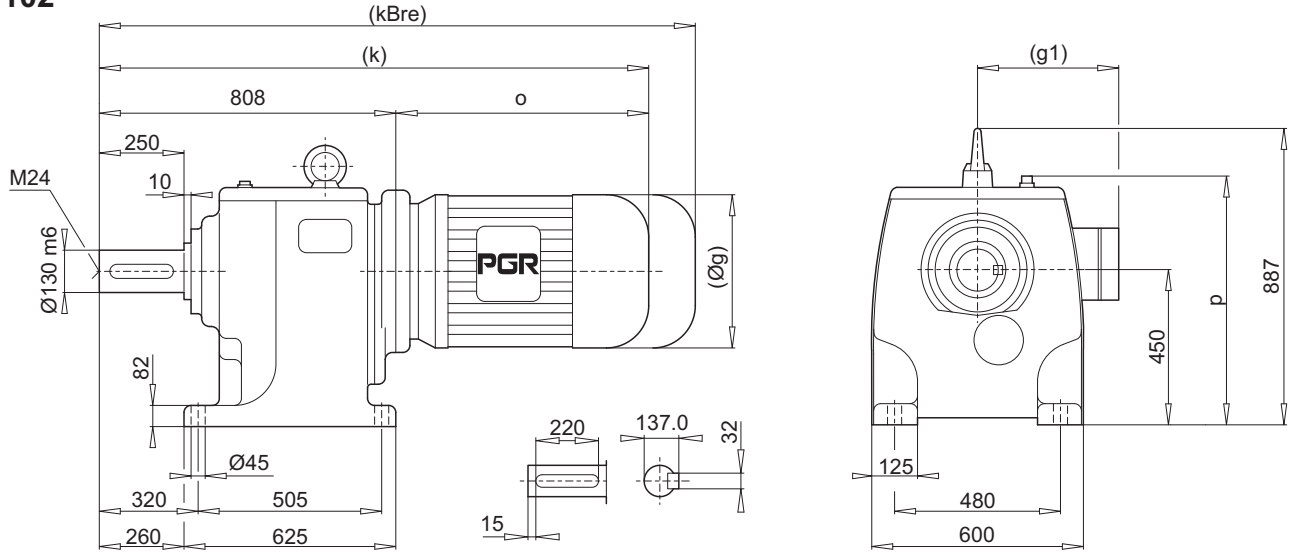

**PF 102**

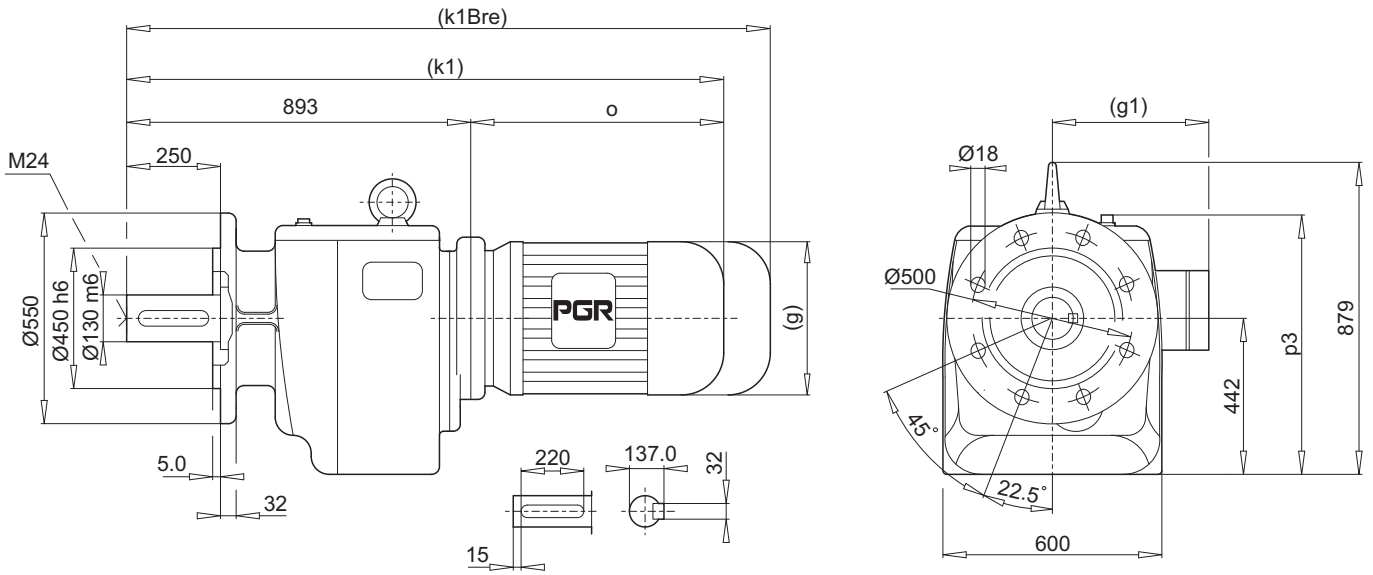

	250 M	280 S	280 M	315 S	315 M			
g	495	-	-	-	-			
g1	392	-	-	-	-			
k	1603	-	-	-	-			
kBre	1858	-	-	-	-			
k1	1688	-	-	-	-			
k1Bre	1943	-	-	-	-			
o	795	-	-	-	-			
p	702	-	-	-	-			
p3	706	-	-	-	-			

**Not** : (...) İşaretili olan ölçüler Motor markasına göre farklılık gösterir.  
Note : Dimension which is designated by (...) depends on marks of motor.



**PA 103**

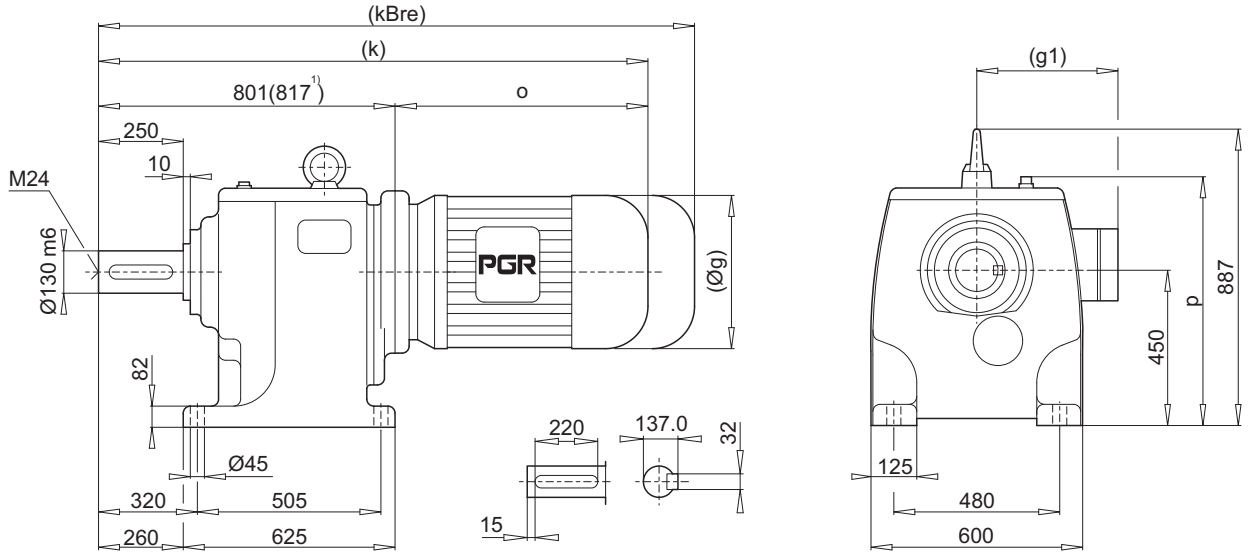

**PF 103**

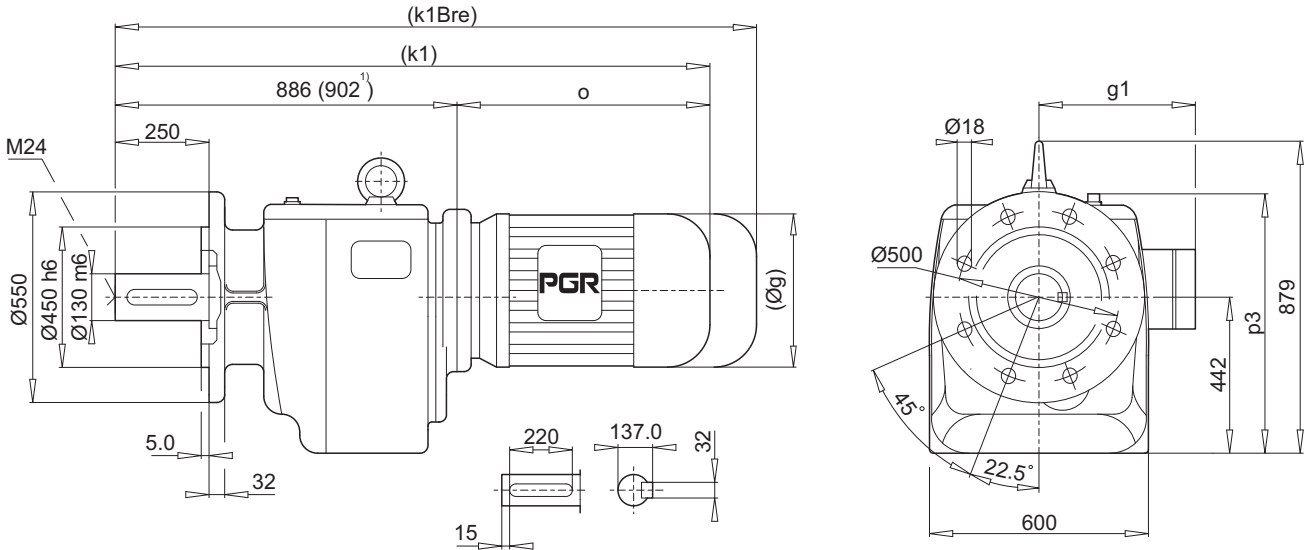

	132 S/M	160 M/L	180 M/L	200 L	225 S/M	250 M <sup>1)</sup>	280 S <sup>1)</sup>	280 M <sup>1)</sup>	315 S <sup>1)</sup>	315 M <sup>1)</sup>
g	279	323	370	415	456	495	-	-	-	-
g1	182	200	248	260	260	392	-	-	-	-
k	1214	1284	1324	1493	1493	1612	-	-	-	-
kBre	1322	1436	1486	1640	1665	1867	-	-	-	-
k1	1299	1369	1409	1578	1578	1697	-	-	-	-
k1Bre	1407	1521	1571	1725	1750	1952	-	-	-	-
o	413	483	523	692	692	795	-	-	-	-
p	702	702	702	702	702	710	-	-	-	-
p3	706	706	706	706	706	710	-	-	-	-

**Not** : (...) İşaretili olan ölçüler Motor markasına göre farklılık gösterir.  
Note : Dimension which is designated by (...) depends on marks of motor.