

PG 14000

| | i | Mc [kNm] | | | | n _{1max} [min ⁻¹] | Pt [kW] | Kg | | | | |
|-----------------|-----------------|--------------------|--------------------|--------------------|--------------------|---|------------|-----|---|-----|-----|-----|
| | | n ₂ x h | n ₂ x h | n ₂ x h | n ₂ x h | | | M | P | CPC | F | FS |
| | | 10.000 | 20.000 | 50.000 | 100.000 | | | | | | | |
| PG 14001 | 3.83 | 156.6 | 140.9 | 122.7 | 115.0 | 200 | 75 | 685 | — | — | 615 | 628 |
| | 4.40 | 144.8 | 130.3 | 113.4 | 110.0 | | | | | | | |
| PG 14002 | 15.33 | 156.6 | 140.9 | 122.7 | 115.0 | 1500 | 60 | 805 | — | — | 735 | 773 |
| | 18.04 | 156.6 | 140.9 | 122.7 | 115.0 | | | | | | | |
| | 20.71 | 144.8 | 130.3 | 113.4 | 110.0 | | | | | | | |
| PG 14003 | 54.52 | 156.6 | 140.9 | 122.7 | 115.0 | 2000 | 40 | 855 | — | — | 785 | 823 |
| | 65.71 | 156.6 | 140.9 | 122.7 | 115.0 | | | | | | | |
| | 75.43 | 144.8 | 130.3 | 113.4 | 110.0 | | | | | | | |
| | 88.74 | 144.8 | 130.3 | 113.4 | 110.0 | | | | | | | |
| | 115.95 | 144.8 | 130.3 | 113.4 | 110.0 | | | | | | | |
| 139.77 | 144.8 | 130.3 | 113.4 | 110.0 | | | | | | | | |
| PG 14004 | 205.96 | 156.6 | 140.9 | 122.7 | 115.0 | 2800 | 30 | 871 | — | — | 801 | 839 |
| | 248.25 | 156.6 | 140.9 | 122.7 | 115.0 | | | | | | | |
| | 271.07 | 156.6 | 140.9 | 122.7 | 115.0 | | | | | | | |
| | 281.68 | 156.6 | 140.9 | 122.7 | 115.0 | | | | | | | |
| | 311.14 | 144.8 | 130.3 | 113.4 | 110.0 | | | | | | | |
| | 335.24 | 144.8 | 130.3 | 113.4 | 110.0 | | | | | | | |
| | 380.38 | 144.8 | 130.3 | 113.4 | 110.0 | | | | | | | |
| | 395.26 | 156.6 | 140.9 | 122.7 | 115.0 | | | | | | | |
| | 443.64 | 156.6 | 140.9 | 122.7 | 115.0 | | | | | | | |
| | 476.43 | 156.6 | 140.9 | 122.7 | 115.0 | | | | | | | |
| | 546.86 | 144.8 | 130.3 | 113.4 | 110.0 | | | | | | | |
| | 599.09 | 144.8 | 130.3 | 113.4 | 110.0 | | | | | | | |
| | 643.36 | 144.8 | 130.3 | 113.4 | 110.0 | | | | | | | |
| | 695.72 | 144.8 | 130.3 | 113.4 | 110.0 | | | | | | | |
| | 840.66 | 144.8 | 130.3 | 113.4 | 110.0 | | | | | | | |
| | 1113.29 | 144.8 | 130.3 | 113.4 | 110.0 | | | | | | | |
| | PG 14005 | 732.30 | 156.6 | 140.9 | 122.7 | | | | | | | |
| 799.61 | | 156.6 | 140.9 | 122.7 | 115.0 | | | | | | | |
| 882.68 | | 156.6 | 140.9 | 122.7 | 115.0 | | | | | | | |
| 963.81 | | 156.6 | 140.9 | 122.7 | 115.0 | | | | | | | |
| 1001.53 | | 156.6 | 140.9 | 122.7 | 115.0 | | | | | | | |
| 1063.95 | | 156.6 | 140.9 | 122.7 | 115.0 | | | | | | | |
| 1153.37 | | 156.6 | 140.9 | 122.7 | 115.0 | | | | | | | |
| 1207.20 | | 156.6 | 140.9 | 122.7 | 115.0 | | | | | | | |
| 1390.22 | | 156.6 | 140.9 | 122.7 | 115.0 | | | | | | | |
| 1577.40 | | 156.6 | 140.9 | 122.7 | 115.0 | | | | | | | |
| 1693.97 | | 156.6 | 140.9 | 122.7 | 115.0 | | | | | | | |
| 1829.73 | | 156.6 | 140.9 | 122.7 | 115.0 | | | | | | | |
| 2208.00 | | 156.6 | 140.9 | 122.7 | 115.0 | | | | | | | |
| 2661.43 | | 156.6 | 140.9 | 122.7 | 115.0 | | | | | | | |
| 2956.80 | | 144.8 | 130.3 | 113.4 | 110.0 | | | | | | | |
| 3228.56 | | 144.8 | 130.3 | 113.4 | 110.0 | | | | | | | |
| 3691.29 | | 144.8 | 130.3 | 113.4 | 110.0 | | | | | | | |
| 4043.86 | | 144.8 | 130.3 | 113.4 | 110.0 | | | | | | | |
| 5674.45 | | 144.8 | 130.3 | 113.4 | 110.0 | | | | | | | |

PG 14000

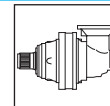

| | i | Mc [kNm] | | | | n1max [min ⁻¹] | Pt [kW] | Kg | | | | |
|------------------|---------|--------------------|--------------------|--------------------|--------------------|-------------------------------|------------|-----|---|-----|-----|-----|
| | | n ₂ x h | n ₂ x h | n ₂ x h | n ₂ x h | | | M | P | CPC | F | FS |
| | | 10.000 | 20.000 | 50.000 | 100.000 | | | | | | | |
| PGA 14004 | 167.45 | 156.6 | 140.9 | 122.7 | 115.0 | 2500 | 28 | 964 | — | — | 894 | 932 |
| | 201.84 | 156.6 | 140.9 | 122.7 | 115.0 | | | | | | | |
| | 272.56 | 144.8 | 130.3 | 113.4 | 110.0 | | | | | | | |
| | 306.67 | 156.6 | 140.9 | 122.7 | 115.0 | | | | | | | |
| | 356.14 | 144.8 | 130.3 | 113.4 | 110.0 | | | | | | | |
| | 414.12 | 144.8 | 130.3 | 113.4 | 110.0 | | | | | | | |
| | 459.95 | 144.8 | 130.3 | 113.4 | 110.0 | | | | | | | |
| | 541.11 | 144.8 | 130.3 | 113.4 | 110.0 | | | | | | | |
| | 652.24 | 144.8 | 130.3 | 113.4 | 110.0 | | | | | | | |
| PGA 14005 | 711.49 | 156.6 | 140.9 | 122.7 | 115.0 | 2800 | 20 | 913 | — | — | 843 | 881 |
| | 857.60 | 156.6 | 140.9 | 122.7 | 115.0 | | | | | | | |
| | 973.07 | 156.6 | 140.9 | 122.7 | 115.0 | | | | | | | |
| | 1074.86 | 144.8 | 130.3 | 113.4 | 110.0 | | | | | | | |
| | 1224.40 | 156.6 | 140.9 | 122.7 | 115.0 | | | | | | | |
| | 1351.61 | 156.6 | 140.9 | 122.7 | 115.0 | | | | | | | |
| | 1514.23 | 144.8 | 130.3 | 113.4 | 110.0 | | | | | | | |
| | 1694.00 | 144.8 | 130.3 | 113.4 | 110.0 | | | | | | | |
| | 1992.94 | 144.8 | 130.3 | 113.4 | 110.0 | | | | | | | |
| | 2146.67 | 156.6 | 140.9 | 122.7 | 115.0 | | | | | | | |
| | 2496.21 | 144.8 | 130.3 | 113.4 | 110.0 | | | | | | | |
| | 2772.46 | 144.8 | 130.3 | 113.4 | 110.0 | | | | | | | |
| | 3138.88 | 144.8 | 130.3 | 113.4 | 110.0 | | | | | | | |
| | 3219.63 | 144.8 | 130.3 | 113.4 | 110.0 | | | | | | | |
| | 3502.74 | 144.8 | 130.3 | 113.4 | 110.0 | | | | | | | |
| | 3931.53 | 144.8 | 130.3 | 113.4 | 110.0 | | | | | | | |
| | 4576.92 | 144.8 | 130.3 | 113.4 | 110.0 | | | | | | | |
| 5516.82 | 144.8 | 130.3 | 113.4 | 110.0 | | | | | | | | |

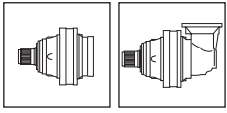

PG 14000

MS

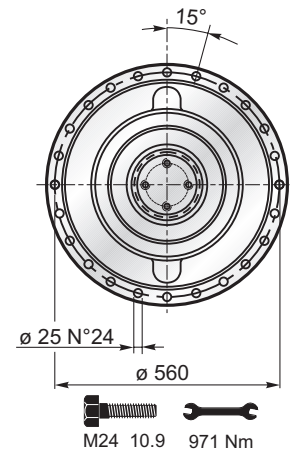
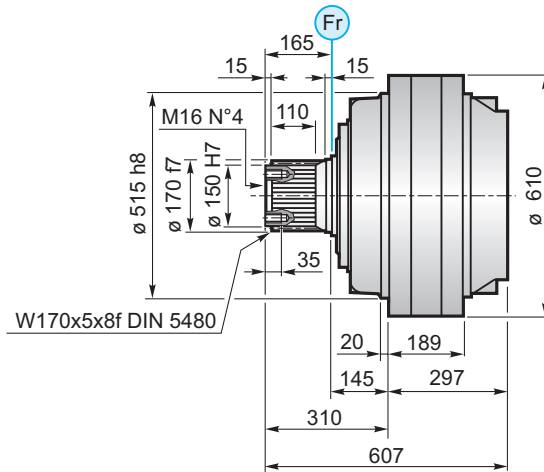
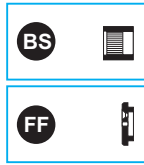

MC

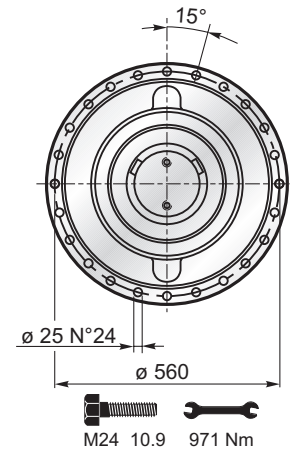
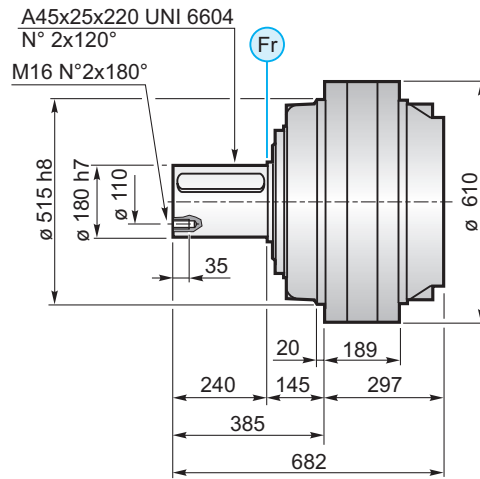

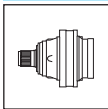

PG 14000

| | PG | | ...MS | | | |
|----------|-------|--------|-------|----|----|-----|
| | A | B | RA | RB | EF | EDF |
| PG 14002 | 494 | 804 | | | | |
| PG 14003 | 581 | 891 | | • | | |
| PG 14004 | 652.5 | 962.5 | • | o | • | |
| PG 14005 | 713.5 | 1023.5 | • | | | • |

| | PG | | ...MC | | | |
|----------|-------|--------|-------|----|----|-----|
| | A | B | RA | RB | EF | EDF |
| PG 14002 | 494 | 879 | | | | |
| PG 14003 | 581 | 966 | | • | | |
| PG 14004 | 652.5 | 1037.5 | • | o | • | |
| PG 14005 | 713.5 | 1098.5 | • | | | • |

| | PG | | ...F | | | |
|----------|-------|-------|------|----|----|-----|
| | A | B | RA | RB | EF | EDF |
| PG 14002 | 494 | 646 | | | | |
| PG 14003 | 581 | 733 | | • | | |
| PG 14004 | 652.5 | 804.5 | • | o | • | |
| PG 14005 | 713.5 | 865.5 | • | | | • |

| | PG | | ...FS | | | |
|----------|-------|--------|-------|----|----|-----|
| | A | B | RA | RB | EF | EDF |
| PG 14002 | 494 | 844 | | | | |
| PG 14003 | 581 | 931 | | • | | |
| PG 14004 | 652.5 | 1002.5 | • | o | • | |
| PG 14005 | 713.5 | 1063.5 | • | | | • |

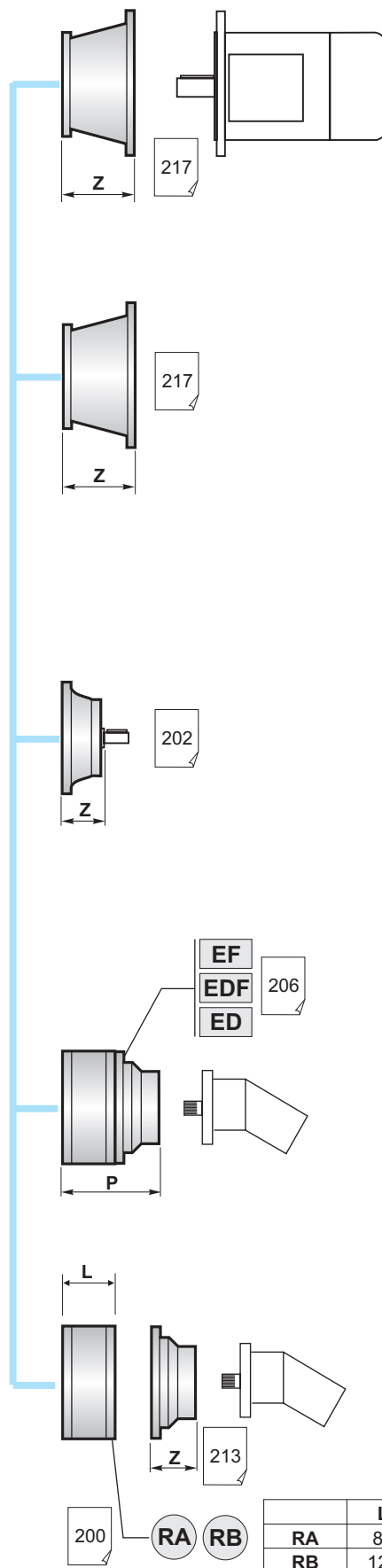

| | | |
|--------|--------|---|
| A | B | • |
| A+13.5 | B+13.5 | o |

| | | | |
|-----|----|----|-----|
| 200 | RA | RB | L |
| | RA | RB | 81 |
| | RA | RB | 125 |

PG 14000

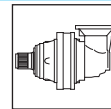

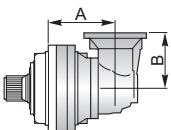
|  | PGA ...MS | | | | |
|---|-----------|-----|----|----|----|
| | A | B | RA | RB | EF |
| PGA 14004 | 716 | 315 | | • | |
| PGA 14005 | 754 | 240 | • | o | • |

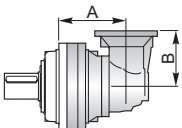
|  | PGA ...MC | | | | |
|---|-----------|-----|----|----|----|
| | A | B | RA | RB | EF |
| PGA 14004 | 716 | 315 | | • | |
| PGA 14005 | 754 | 240 | • | o | • |

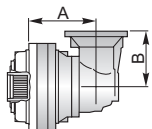
|  | PGA ...F | | | | |
|---|----------|-----|----|----|----|
| | A | B | RA | RB | EF |
| PGA 14004 | 716 | 315 | | • | |
| PGA 14005 | 754 | 240 | • | o | • |

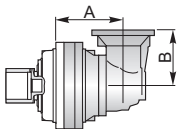
|  | PGA ...FS | | | | |
|--|-----------|-----|----|----|----|
| | A | B | RA | RB | EF |
| PGA 14004 | 716 | 315 | | • | |
| PGA 14005 | 754 | 240 | • | o | • |

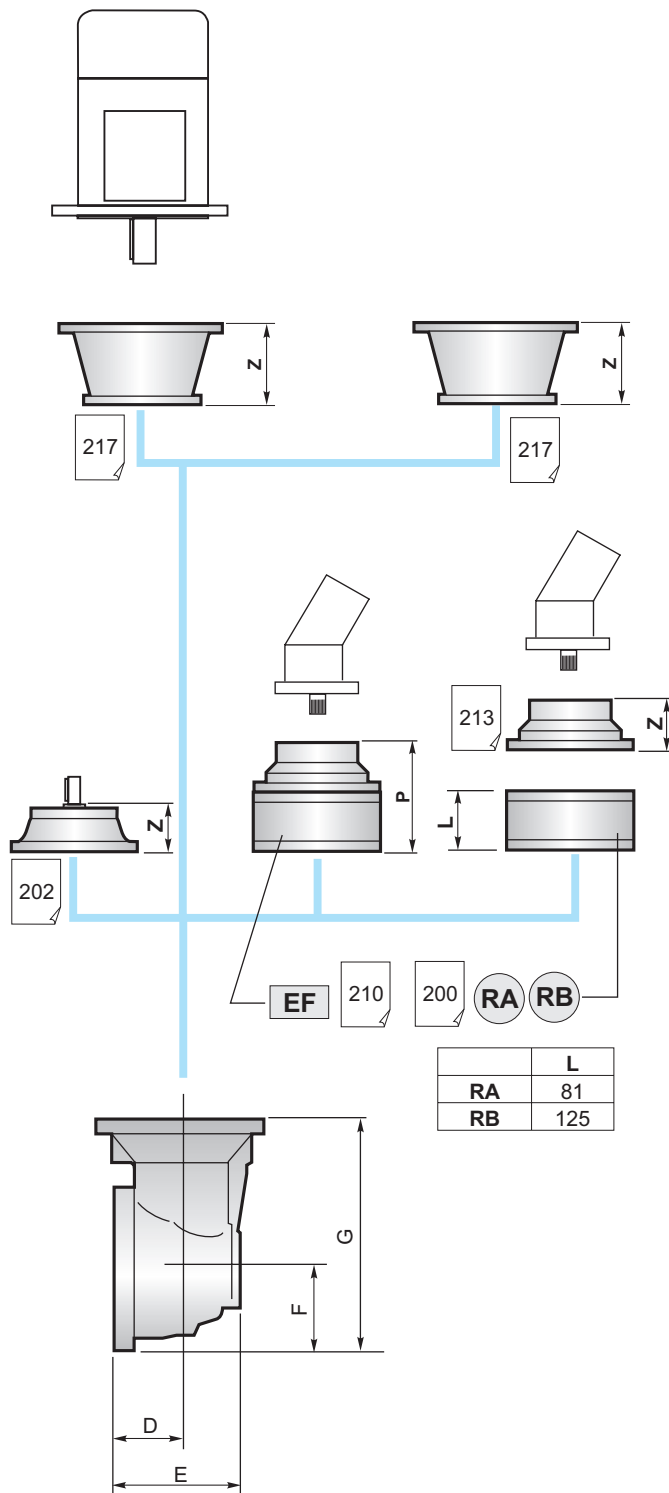

| | D | E | F | G |
|-----------|----|-----|-----|-----|
| PGA 14004 | 88 | 256 | 235 | 550 |
| PGA 14005 | 88 | 164 | 140 | 380 |

| | | |
|---|--------|---|
|  | B | • |
| | B+16.5 | o |

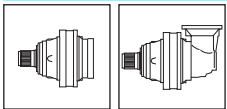

PG 14000

BS Boccola scanalata / Splined bushing
Moyeu cannelé / Innenverzahnte Buchse

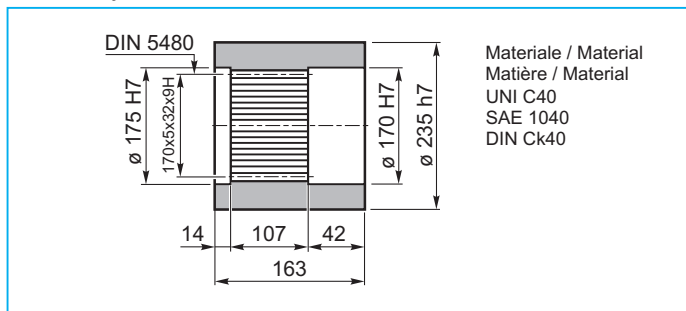

FF Fondello di arresto / Stop bottom plate
Bouchon de fermeture / Endscheibe

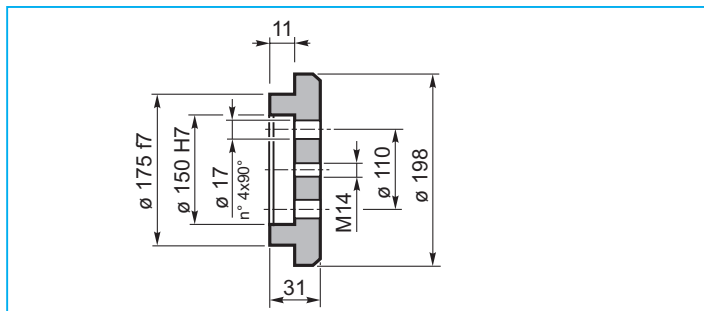

GA Giunto di attrito / Shrink disc
Frette de serrage / Schrumpfscheibe

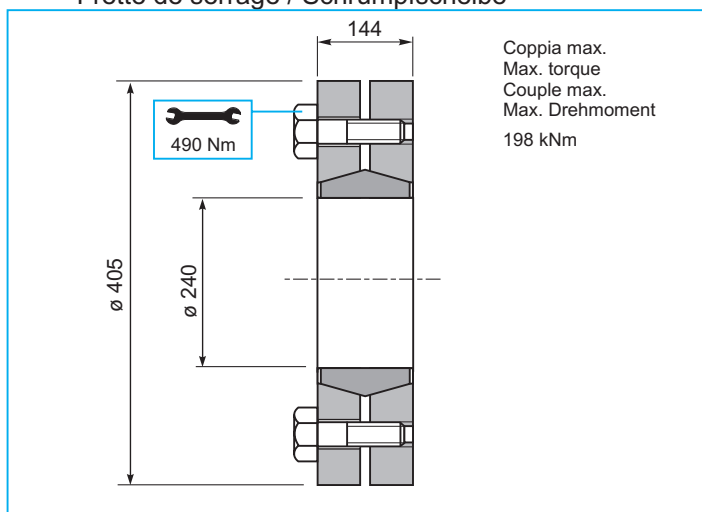

PG 14000

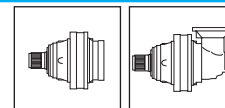

CARICHI RADIALI (Fr)

Nei diagrammi seguenti sono riportati i carichi radiali e i coefficienti K per rapportarli al valore $n_2 \times h$ desiderato.

RADIAL LOADS (Fr)

The following curves show the radial loads and the K factors to obtain the required $n_2 \times h$ value.

CHARGES RADIALES (Fr)

Dans les diagrammes suivants sont indiqués les charges radiales et les facteurs K de façon à obtenir la valeur $n_2 \times h$ désirée.

RADIALLAST (Fr)

In den nachstehenden Diagrammen ist die Radiallast und der Koeffizient K dargestellt und kann mit dem gewünschten Wert $n_2 \times h$ verglichen werden.

M

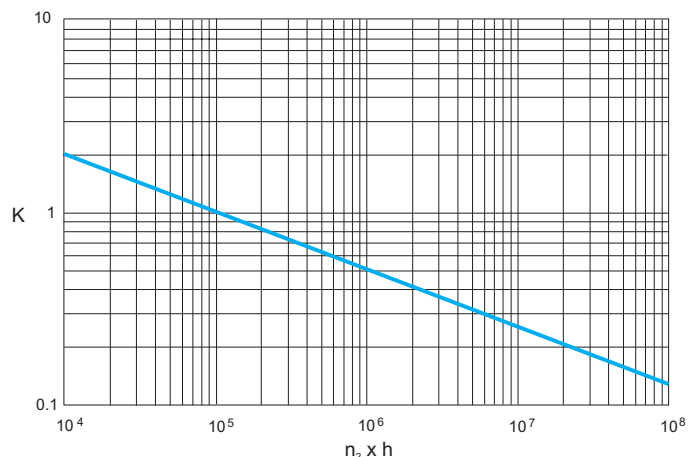
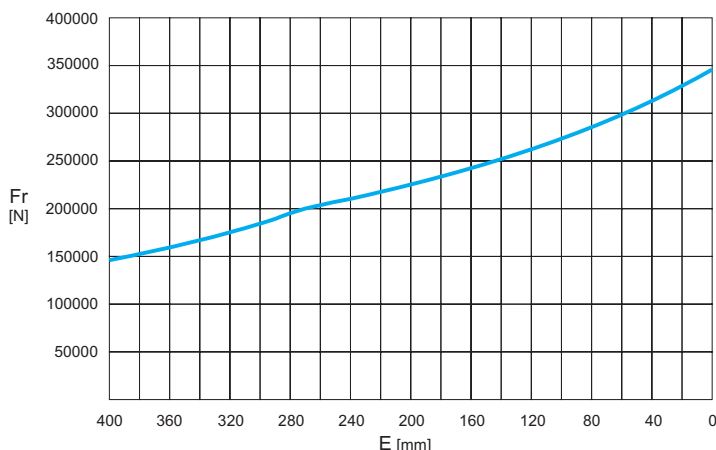

| M | $n \times h$ | | | | |
|---|--------------|--------|--------|--------|--------|
| | 10^5 | 10^4 | 10^6 | 10^7 | 10^8 |
| | Fr | | Fr • K | | |

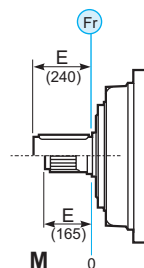

CARICHI ASSIALI (Fa)

I valori dei carichi assiali indicati in tabella sono riferiti alle versioni e alla direzione di applicazione del carico.

AXIAL LOADS (Fa)

The values of the axial loads in the table refer to the output versions and load direction of application.

CHARGES AXIALES (Fa)

Les valeurs des charges axiales indiquées dans le tableau se réfèrent aux versions et à la direction d'application de la charge.

AXIALLAST (Fa)

Die dargestellten Werte der Axiallast basieren auf der Version und der applizierten Lastrichtung.

| Fa [N] | M | |
|-----------|-------|-------|
| | | 45000 |
| | 45000 | → |

